



The British *Power Conversion* Company

**BPC561-01  
POWER GEM PLUS RTV2 1-3KVA  
USER MANUAL**



# CONTENTS

CHAPTER 1 – SAFETY WARNINGS .....	4
1.1 DESCRIPTION OF SYMBOLS USED IN THIS MANUAL .....	4
1.2 GENERAL WARNINGS .....	4
1.3 BATTERY SAFETY .....	5
CHAPTER 2 – GENERAL DESCRIPTION .....	6
2.1 INTRODUCTION .....	6
2.2 REAR PANEL VIEW .....	7
2.3.1 1KVA .....	7
2.3.2 2KVA .....	7
2.3.3 2KVA .....	8
2.3.4 REAR PANEL DESCRIPTION .....	8
2.3 DISPLAY PANEL .....	9
2.3.1 LED INDICATORS .....	10
2.3.2 FUNCTION KEYS .....	10
2.3.3 LCD DISPLAY ICONS .....	11
2.3.4 BUTTON OPERATION .....	12
2.3.5 DISPLAY SCREENS .....	13
CHAPTER 3 – INSTALLATION .....	15
3.1 INTRODUCTION .....	15
3.2 ACCEPTING DELIVERY .....	15
3.2.1 REPORTING DAMAGE .....	15
3.2.2 STORAGE .....	15
3.3 INSTALLATION .....	16
3.3.1 ENVIRONMENTAL CONSIDERATIONS .....	16
3.3.2 CLEARANCES .....	16
3.3.4 CABLE CONSIDERATIONS .....	17
3.3.5 RACKMOUNT UPS INSTALLATION .....	17
3.3.6 TOWER INSTALLATION .....	19
3.3.7 INTERNAL BATTERY CONNECTION .....	22
3.3.8 EXTERNAL BATTERY CONNECTION .....	23
CHAPTER 4 – EXTENDABLE BATTERY CABINETS .....	24
CHAPTER 5 – OPERATION INSTRUCTIONS .....	26

5.1 START UP.....	26
5.1.1 START UP UPS FROM MAINS .....	26
5.1.2 START UP UPS FROM BATTERY .....	26
5.1.3 SHUTDOWN OPERATION .....	26
CHAPTER 6 – SETTINGS INSTRUCTIONS .....	27
6.1 START UP.....	27
CHAPTER 7 – MAINTENANCE INSTRUCTIONS .....	31
CHAPTER 8 – TROUBLE SHOOTING .....	31
8.1 ALARMS AND WARNING MESSAGES.....	32
8.2 POSSIBLE CAUSE .....	33
CHAPTER 9 – COMMUNICATION .....	34
9.1 INTRODUCTION .....	34
9.2 USB Port .....	34
9.3 INTELLIGENT CARD SLOT .....	34
9.3.1 SNMP - OPTIONAL.....	34
9.3.2 RELAY – DRY PORT - OPTIONAL.....	35
9.4 EPO EMERGENCY POWER OFF .....	35
CHAPTER 10 – TECHNICAL SPECIFICATION .....	36

## CHAPTER 1 – SAFETY WARNINGS

Read the following safety information carefully before you install or operate the BPC PowerGemPlus RT (PGPRT) UPS equipment and keep this manual within easy access of the equipment for future reference.

### 1.1 DESCRIPTION OF SYMBOLS USED IN THIS MANUAL



**WARNING:** The warning symbol is used where there is danger of an electrical shock, equipment damage or personal injury.



**CAUTION:** The caution symbol is used to highlight important information to avoid possible equipment malfunction or damage.

### 1.2 GENERAL WARNINGS



**WARNING:** Be aware that the output from this equipment can be energized when the unit is not connected to a mains supply, even when the input AC power is disconnected



**WARNING:** The PGPRT assembly and peripheral equipment must be installed and commissioned by suitably qualified and trained personnel who are aware of the potential shock hazards.



**WARNING:** The PGPRT must be supplied by a grounded outlet. Do not operate the unit without a ground source.



**WARNING:** To reduce the risk of electric shock:

- Do not insert any object into ventilation holes or other openings
- Do not remove any equipment cover – the unit does not contain any user-serviceable parts. Refer all servicing requirements to qualified service personnel.
- Always disconnect the PGPRT from the mains power supply before you install a computer interface signal cable. Reconnect the power only after the signalling interface connections have been made.



**WARNING:** To reduce the risk of fire:

- Install this equipment in a temperature and humidity controlled indoor area free of conductive contaminants.
- If a fuse ruptures always replace it with a fuse of the same type and rating.

### 1.3 BATTERY SAFETY



**WARNING:** The battery is not isolated from the mains voltage. Hazardous voltage may occur between the battery terminals and ground.



**WARNING:** A battery can present a risk of electric shock or burn from high short circuit currents. Always take the following precautions when working on batteries:

- Remove watches, rings or other metal objects.
- Use tools with insulated handles.



**WARNING:** The PGPRT system uses recyclable batteries:

- The batteries contain lead and pose a hazard to the environment and human health if not disposed of properly.
- If you replace the batteries you must dispose of the used batteries in accordance with local environmental laws and regulations.



**WARNING:** Heed the following warnings concerning battery handling:

- Do not dispose of batteries in a fire. The batteries may explode.
- Do not open or mutilate the batteries. They contain an electrolyte which is toxic and harmful to the skin and eyes.
- If electrolyte comes into contact with the skin, the affected area should be washed immediately with clean flowing water.
- The internal energy source (the battery) cannot be de-energized by the user.



**WARNING:** When changing the batteries, install the same number and type of batteries.

## CHAPTER 2 – GENERAL DESCRIPTION

### 2.1 INTRODUCTION

BPC PGPRT UPS systems are double conversion topology, manufactured with the latest IGBT and PWM technology, to produce pure sine wave output.

BPC PGPRT Series units are 1-phase in/1-phase out devices, and they are installed between a single-phase load, and a 1-phase+N mains supply.

The advantages of using PGPRT:

*Power blackout protection:*

If the mains power fails, the PGPRT continues to supply the critical load using the energy stored in its batteries, keeping the load immune from power disturbances.

*Increased power quality:*

The PGPRT has its own internal voltage and frequency regulating software, which ensures that its output to the critical load is maintained within close tolerances, independent of voltage and frequency variations on the mains power lines.

#### KEY FEATURES

- Pure sinusoidal output wave form and true on-line topology
- High input power factor, Input current limiting
- Low input current THD
- Low output voltage THD
- High AC/AC and DC/AC efficiency (up to 90%)
- High charger capacity
- Cold-start feature
- Static By-Pass
- LCD alphanumeric display panel providing battery, load, voltage, power and status information in detail to user.
- Improved diagnostics and correct fault information
- Overload operation continuous at 100%-120% load, 10 minutes at 120%-150% load, 1 minute at 150%-180% load
- Output overload, over-current and short circuit protection, output current limiting
- Automatic and manual battery test
- Battery charge with current limiting
- Battery deep discharge protection
- Interactive communication
- Diagnostic and settings with PC ability
- Emergency power-off support
- Conformity to international and local standards
- AC input and output filters
- CE compliance

#### OPTIONAL FEATURES

- Improved remote monitoring panel system
- Direct network connection with optional SNMP support
- MODBUS Adapter

**2.2 REAR PANEL VIEW**

**2.3.1 1KVA**

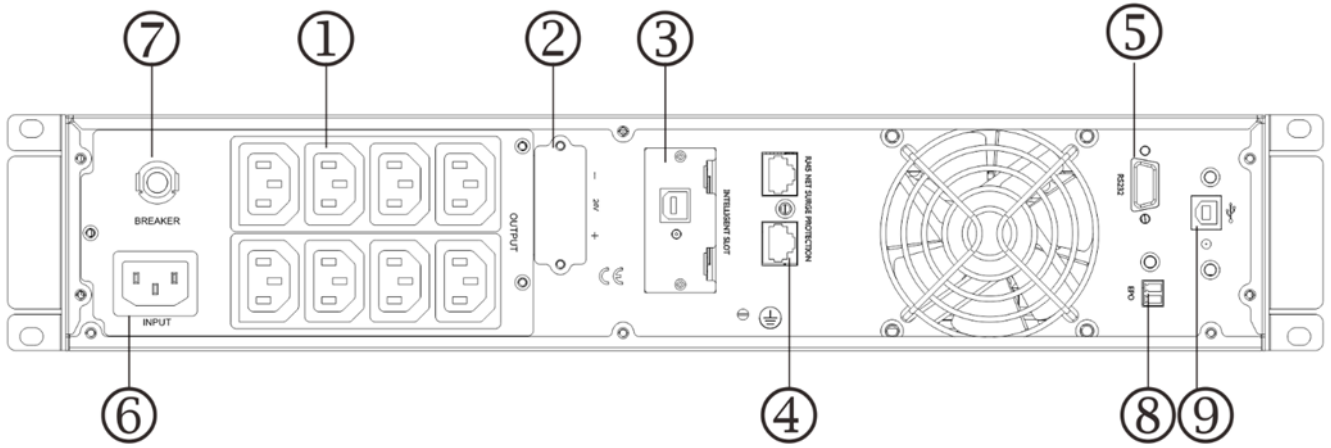

Figure 2.1 – 1Kva Rear Panel

**2.3.2 2KVA**

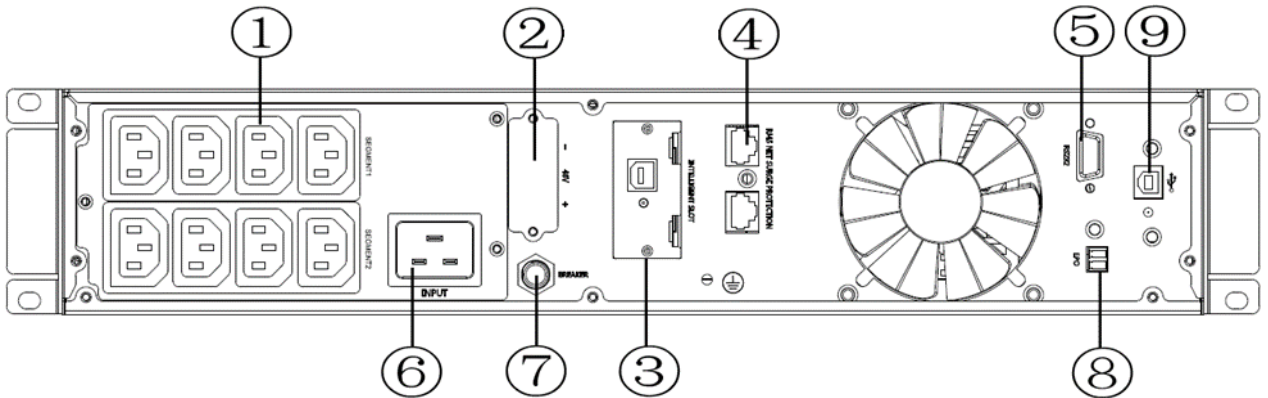

Figure 2.1 – 2Kva Rear Panel

### 2.3.3 2KVA

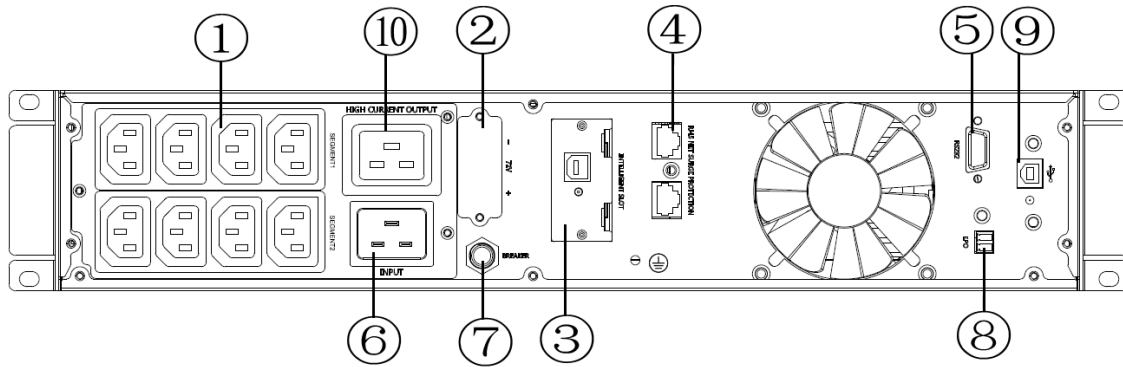

Figure 2.1 – 3Kva Rear Panel

### 2.3.4 REAR PANEL DESCRIPTION

1. Output receptacles (10A)
2. Battery Terminal
3. SNMP intelligent slot (option)
4. Network /Fax/Modem Surge Protection(option)
5. RS-232 communication port
6. AC input receptacle
7. Input circuit breaker
8. EPO
9. USB
10. Output receptacle (16A)





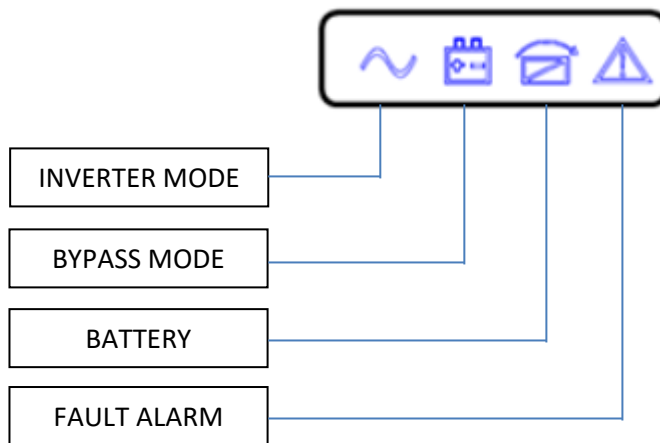
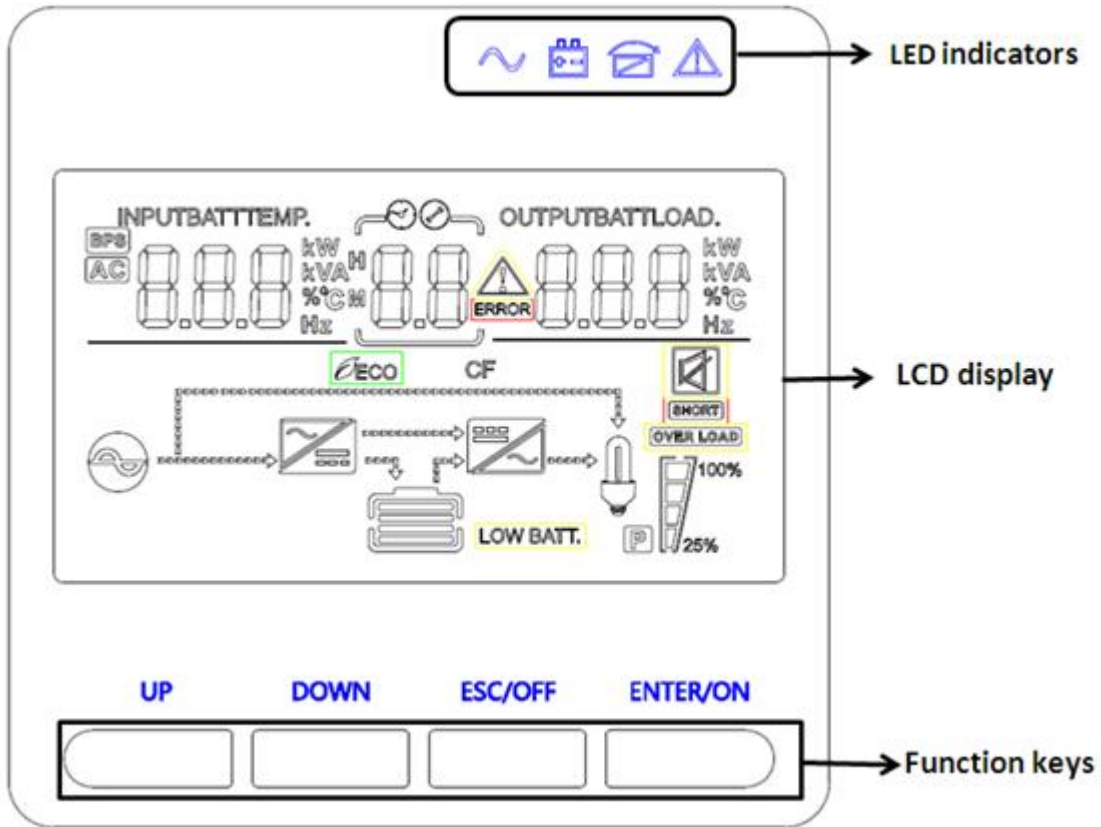

### 2.3 DISPLAY PANEL

The operation and display panel shown in the below chart, is on the front panel of the inverter. It includes three indicators, four function keys, an LCD display, indicating the operating status and input/output power information.



### 2.3.1 LED INDICATORS







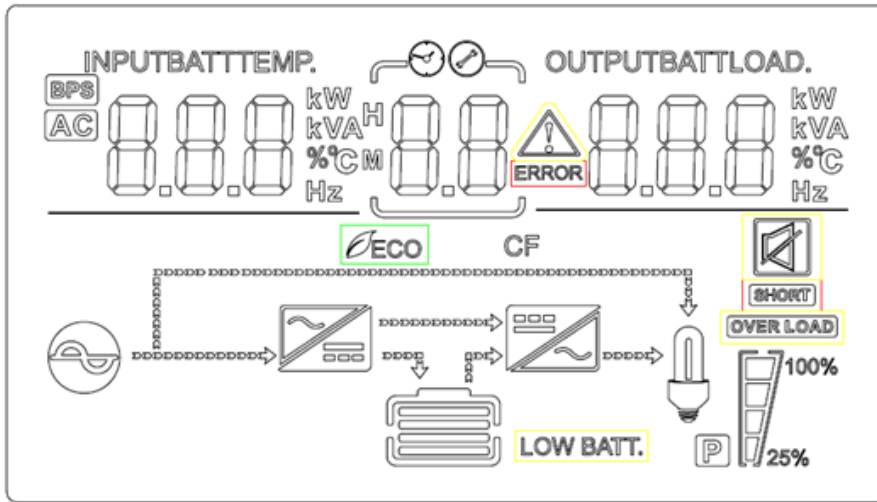

INDICATOR	DESCRIPTION
 Red	IF ACTIVE THE UPS HAS AN ACTIVE ALARM OR FAULT.
 Yellow	IF ACTIVE THE UPS IS IN BYPASS MODE.  IF ACTIVE THE UPS IS OPERATING NORMALLY ON BYPASS DURING ECO MODE.
 Yellow	IF ACTIVE THE UPS IS IN BATTERY MODE.
 Green	IF ACTIVE THE UPS IS OPERATING NORMALLY ON MAINS SUPPLY.
NOTE When power on or startup , these indicators will turn on and off sequentially.  NOTE On different operation modes , these indicators will indicate differently.	







### 2.3.2 FUNCTION KEYS

FUNCTION KEY	DESCRIPTION
ESC/OFF	TO EXIT SETTING MODE / TURN OFF UPS
UP	TO GO TO PREVIOUS SELECTION
DOWN	TO GO TO NEXT SELECTION
ENTER/ON	TO CONFIRM THE SELECTION IN SETTING MODE OR ENTER SETTING MODE OR TO TURN OFF THE UPS

### 2.3.3 LCD DISPLAY ICONS



ICON	FUNCTION / DESCRIPTION
<b>INPUT SOURCE INFORMATION</b>	
	Indicates the AC input.
	Indicates input voltage, input frequency, battery voltage and temperature
<b>CONFIGURATION PROGRAM AND FAULT INFORMATION</b>	
	Indicates the setting programs.
	Indicates the warning and fault codes.
Warning: 	Flashing with warning code.
Fault: 	Lit with fault code
<b>OUTPUT INFORMATION</b>	
	Indicates output voltage, output frequency, load percent, load in VA, load in Watt, and discharging current.
<b>BATTERY INFORMATION</b>	
	Indicates battery level by bars in battery mode and charging status in line mode. 0-24% - 4 bars will flash 25-49%, - Bottom bar will be on, and the other three bars will flash. 50-74% - Bottom two bars will be on, and the other two bars will flash 75-100% - Bottom three bars will be on, and the top bars will flash

ICON	FUNCTION / DESCRIPTION
<b>LOAD INFORMATION</b>	
	Indicates overload.
	Indicates load level by bars: 0-24% - 1 Bar 25-49% - 2 Bars 50-74% - 3 Bars 75-100% - 4 Bars
<b>MODE OPERATION INFORMATION</b>	
	Unit is connected to Mains Supply
	Load is Connected to Mains Supply
	Indicates Rectifier is Operational
	Indicates the Inverter is Operational
<b>MUTE OPERATION</b>	
	Indicates unit alarm is disabled.

### 2.3.4 BUTTON OPERATION

BUTTON	OPERATION
<b>ON /ENTER BUTTON</b>	<ul style="list-style-type: none"> <li>Turn on the UPS: Press and hold ON button for at least 2 seconds to turn on the UPS.</li> <li>Confirm current settings: When the UPS enters the setting mode, must press this button to confirm the settings value.</li> <li>Transfer to Inverter from Bypass : when the UPS is in bypass mode, press and hold this button it will switch to normal mode.</li> </ul>
<b>OFF/ESC BUTTON</b>	<ul style="list-style-type: none"> <li>Turn off the UPS: Press and hold this button at least 2 seconds to turn off the UPS in battery mode.</li> <li>Transfer to Bypass: Press and hold this button at least 2 seconds to transfer the UPS to Bypass mode if the Bypass enable setting is active.</li> <li>Exit setting mode: Press this button to exit setting mode when in UPS setting mode, but save nothing.</li> </ul>
<b>UP BUTTON</b>	<ul style="list-style-type: none"> <li>UP key: Press this button to display previous selection in UPS setting mode.</li> </ul>
<b>DOWN BUTTON</b>	<ul style="list-style-type: none"> <li>Down key: Press this button to display next selection in UPS setting mode.</li> <li>To confirm selection and exit setting mode: Press this button to confirm selection and exit setting mode when LCD display the last selection in UPS setting mode.</li> </ul>
<b>UP + DOWN BUTTON</b>	Setting mode: Press and hold this button for 5 seconds to enter UPS setting mode.

### 2.3.5 DISPLAY SCREENS

SCREEN 1 - INPUT VOLTAGE AND OUTPUT VOLTAGE

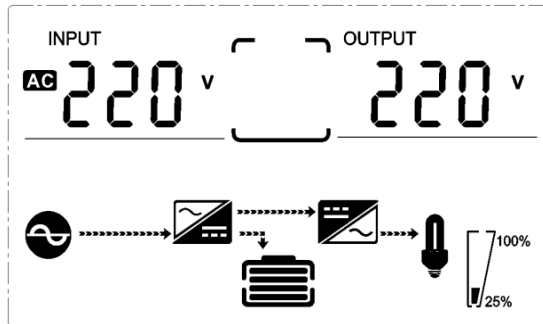

SCREEN 2 - INPUT FREQUENCY & OUTPUT FREQUENCY

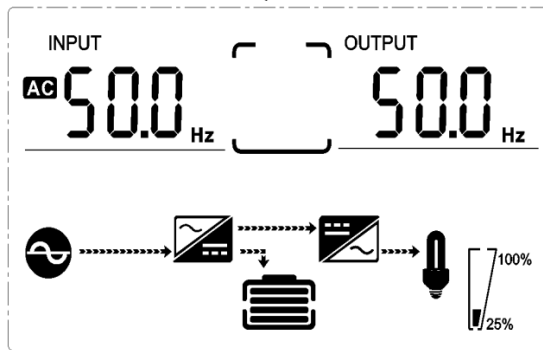

SCREEN 3 - INPUT FREQUENCY, OUTPUT FREQUENCY, BATTERY VOLTAGE, BACKUP TIME & BATTERY CAPACITY

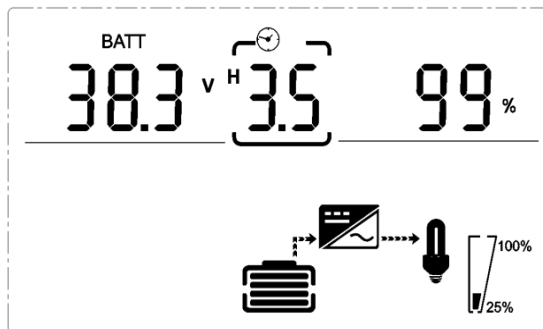

SCREEN 4 - LOAD KW/KVA

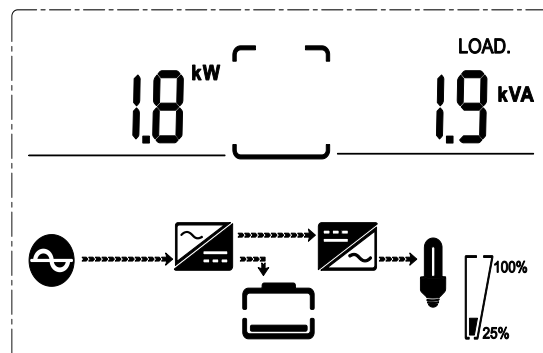

SCREEN 5 - ENVIRONMENT TEMPERATURE

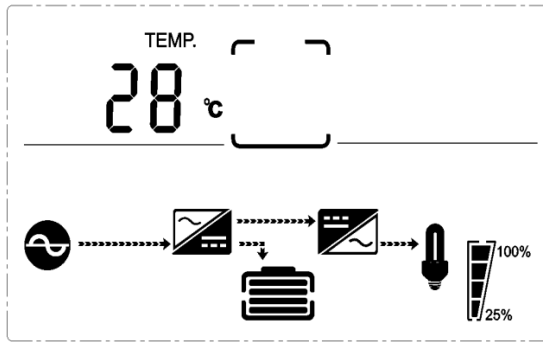

SCREEN 6 - UPS MODEL

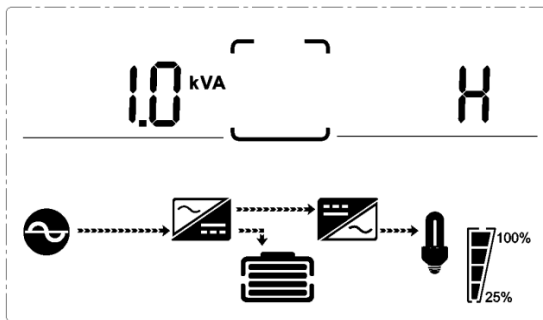

SCREEN 7 - FIRMWARE VERSION

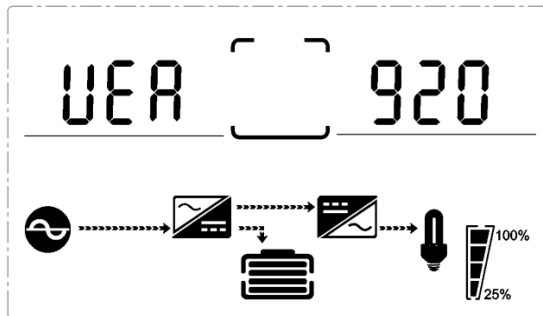

SCREEN 8 - ALARM CODE – SHOWN IN CENTRE ON ALL SCREENS

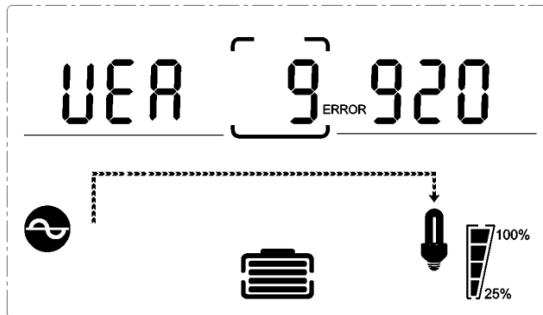

## CHAPTER 3 – INSTALLATION

### 3.1 INTRODUCTION



**WARNING:** All the operations described in this chapter must be supervised by suitably qualified personnel, and all aspects of the electrical installation must be carried out by an authorised electrician.

BPC Energy Ltd. will take no responsibility for any personal injury or material damage caused by incorrect cabling or operation, nor installation activities that are not carried out in strict accordance with the instructions contained in this manual.



**WARNING:** Once the PGPRT system is installed it must be commissioned by an engineer approved by BPC Energy Ltd, or one of its service agents, before it is powered-up.

BPC Energy Ltd. will take no responsibility for any personal injury or material damage caused by the application of electrical power to this equipment before it has been fully commissioned.

### 3.2 ACCEPTING DELIVERY

The PGPRT UPS cabinet is shipped on a purpose-built box that is easy to move by hand or a pallet truck. The accessories are shipped separately.



**CAUTION:** Observe the following precautions when off-loading and moving the cabinet:

- Always keep the packages in an upright position.
- Do not drop the equipment.
- Do not stack the pallets.

The cabinet is packed in a cardboard box that is designed to protect it from mechanical and environmental damage. Further protection is provided by wrapping the equipment with a plastic sheet.

Before you accept the shipment, ensure that the received package(s) correspond to the description shown in the delivery documentation, and carefully examine the packing containers for signs of physical damage.

#### 3.2.1 REPORTING DAMAGE

Claims for shipping damage must be filed immediately when found, and the carrier must be informed of ALL claims within seven days of receipt of the equipment. If the equipment is to be stored for longer than seven days before it is installed, you should unpack it and inspect it for signs of internal damage before you put it into storage. Note that some optional equipment packages might be shipped inside the cabinet, and these too should be checked for damage.

If the equipment is damaged, you should store the packing materials for further investigation.

#### 3.2.2 STORAGE

If you plan to store the PGPRT prior to its installation it should be kept upright (preferably in its original shipping packaging) in a clean, dry environment, with a temperature between -25°C to +60°C and RH <93%.

If the storage period is likely to exceed seven days, the packaging should be removed and the cabinet inspected for shipping damage before it is placed into storage. If there is no apparent damage, you should refit the packaging or cover the cabinet with a dustcover to prevent the ingress of dust and dirt.

Batteries that are intended for external rack-mounting will be shipped in a separate package and should be stored under the environmental conditions stipulated above.

### 3.3 INSTALLATION

#### 3.3.1 ENVIRONMENTAL CONSIDERATIONS

A certain amount of pre-planning will help provide a trouble-free installation process. You should consider the following guidelines when planning the installation location and operating environment.

1. The route to the installation location must allow the equipment to be transported in an upright position.
2. The floor at the proposed installation site and en-route from the off-loading point must be able to safely support the weight of the cabinet/battery equipment, plus forklift or trolley jack during transit.
3. The cabinet requires sufficient front and rear clearance to enable cooling airflow, as described below.
4. All maintenance, servicing and user operation can be carried out from the front of the cabinet, but rear access is required for connecting the AC and DC power cables.
5. An ambient temperature of 20°C is necessary to achieve the recommended battery life span.
6. The cooling air entering the cabinet must not exceed +40°C.
7. The floor material should be non-flammable and strong enough to support the heavy load.

In summary, the system should be installed in a location where:

- a) Humidity (< 93%) and temperature is ideally 20°C.
- b) Fire protection standards are respected.
- c) Cabling can be performed easily.
- d) A minimum 600mm front accessibility is available for service or periodic maintenance.
- e) Adequate cooling air flow is available.
- f) The air conditioning system can provide a sufficient amount of air cooling to keep the room at, or below, the maximum desired temperature (where used).
- g) No dust or corrosive/explosive gases are present.
- h) The location is vibration free.

#### 3.3.2 CLEARANCES

Cooling air enters the front of the power modules and force ventilate through the cabinet rear.

- A. You should provide a minimum of 600mm clearance at the front of the cabinet to allow the power module(s) to be removed/installed.
- B. You should provide a minimum of 300mm at the rear of the cabinet.

The Large extended battery installation is bespoke, and specific access clearances will be specified by the battery installation designer.



### 3.3.4 CABLE CONSIDERATIONS

It is the customer's responsibility to design and install the PGPRT supply and distribution circuits, as well as to provide all the external fuses, switchgear and cables required to connect the cabinet.

MODEL	PGPRT1000V2 (L)	PGPRT2000V2 (L)	PGPRT3000V2 (L)
<b>CONNECTIONS</b>			
Input Connector	1 X C14 INPUT SOCKET		1 X C20 INPUT SOCKET
Output Connector	8 X C13 OUTPUT SOCKET		8 X C13 INPUT SOCKET 1 x C19 OUTPUT SOCKET
AC Cables Provided	1 x C13 to UK plug 1 x C14 to C13 Cable		1 x C19 to UK Plug (13A) 1 x C14 to C13 Cable
DC Cables Provided	1 x Anderson Connector – NO cable		

NOTE: for 3kVA UPS using full 100% (3000W) load a 16A input socket should be fitted (Not included)

### 3.3.5 RACKMOUNT UPS INSTALLATION

As standard the UPS is only supplied with the Ears to mount the cabinet into a standard EIA or JIS seismic cabinet.

The OPTIONAL rail assemblies adjust to mount in 19" racks with a distance from front to rear of around 70~76 cm (27 to 30 inches) deep.

NOTE: Mounting Rails are required for each individual cabinet.



**WARNING:** The Cabinet is heavy, hence removing the cabinet from its carton requires a minimum of two people

1. To install the rail kit
  - a. Assemble the left and right rails to the rear rails as shown in Figure 3.1. Do not tighten the screws.
  - b. Adjust each rail size for the depth of your rack.

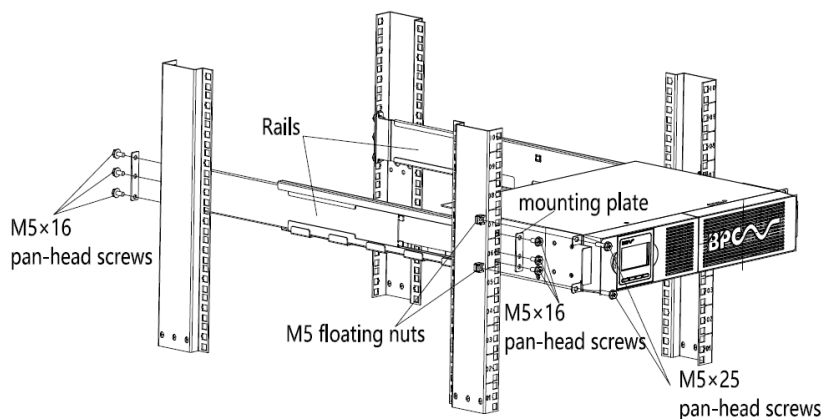

Figure 3.1 Securing the rails to the rack

- c. Place the UPS on a flat, stable surface with the front of the cabinet facing to you.
- d. Align the mounting brackets with the screw holes on each side of the UPS and fix with the supplied M4×8 flat-head screws(see Figure 3.2)

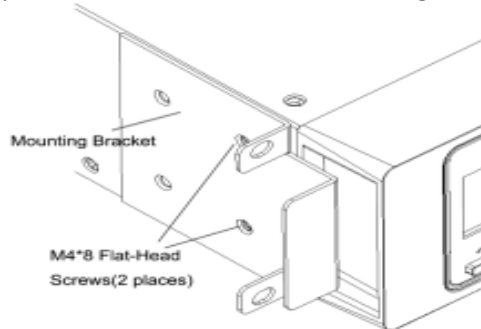

Figure3.2 Installing the Mounting Brackets

- e. If installing optional cabinets, repeat Step c and d for each cabinet.
- f. Slide the UPS and any other optional cabinets into the rack.
- g. Secure the front of the UPS to the rack using one M5×12 pan-head screws and one M5 cage nuts on each side (see Figure 3.3).
- h. Install the bottom screw on each side through the bottom hole of mounting bracket and the bottom hole of the rail.
- i.

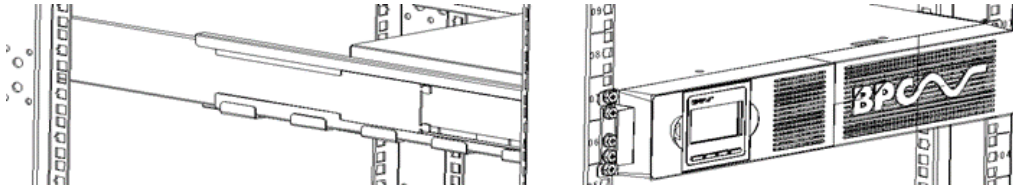

Figure3.3 Securing the Front of the Cabinet

- j. Continue to the following section, “Rackmount Wiring Installation.
- k. Rackmount Wiring Installation
- l. Installing the UPS, including connecting the UPS internal batteries
- m. Connecting any Optional EBP(S)

### 3.3.6 TOWER INSTALLATION

The UPS is supplied with feet for tower installation as standard. Four feet are supplied with the system, these need to be attached together. The feet interlock as shown in Figure 3.4

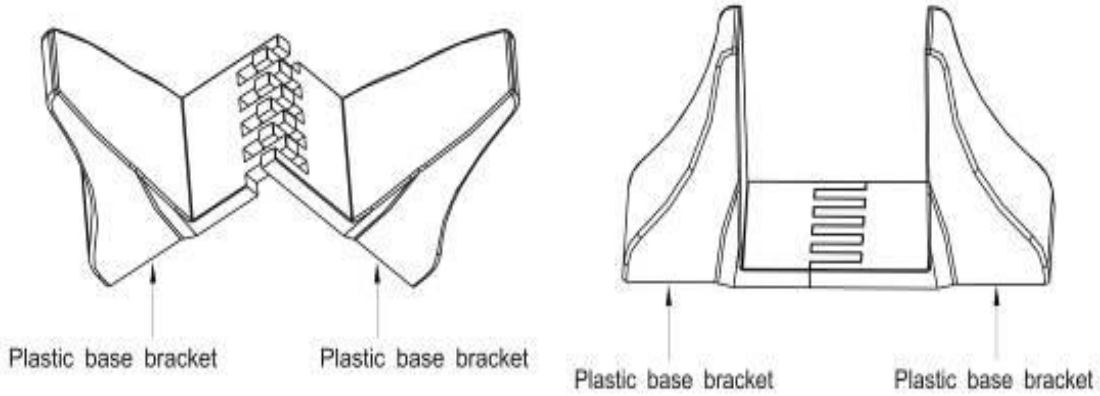

Figure 3.4 plastic base installation

When assembled, the UPS slots into both of the feet as per Figure 3.5

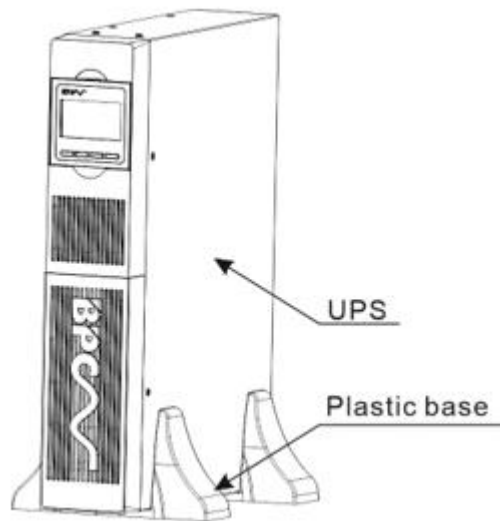

Figure 3.5 UPS to plastic base installation

The display on the UPS can then be converted for Tower Format. The display can be pulled out rotated into the correct position and pushed back into its socket. See Figure 3.6

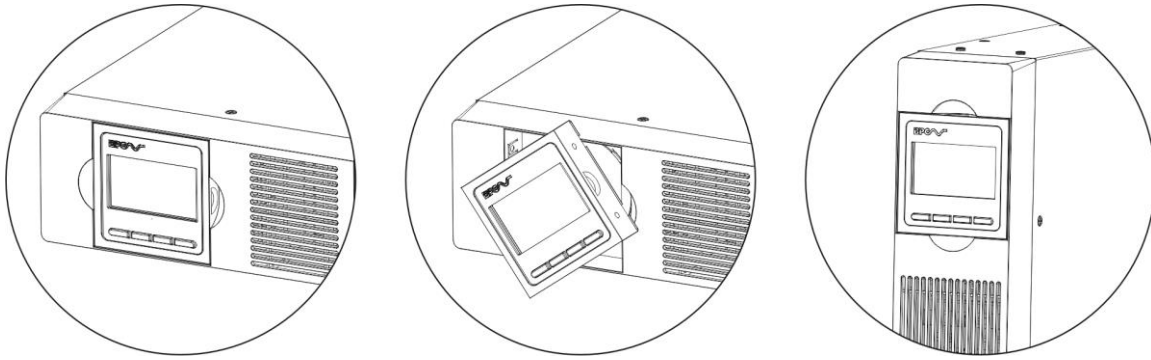
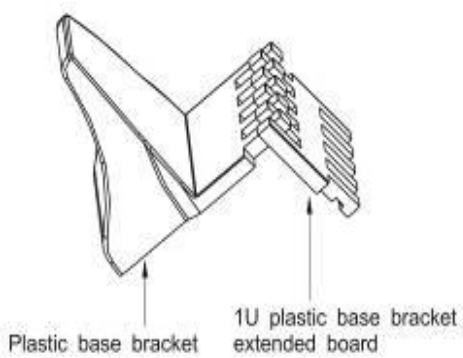
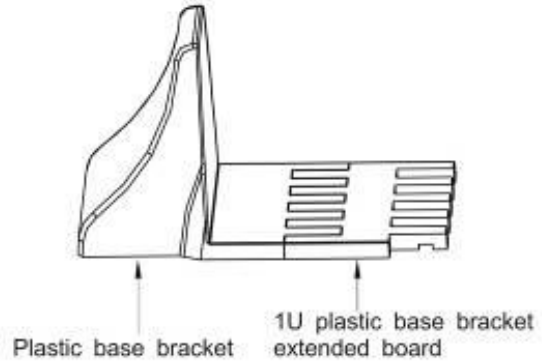

Figure 3.6 Display Rotation

When installing extra battery cabinets the feet will need to be extended, apply the 1U plastic base bracket extending board in between the UPS feet as detailed in Figure 3.7



(A)



(B)

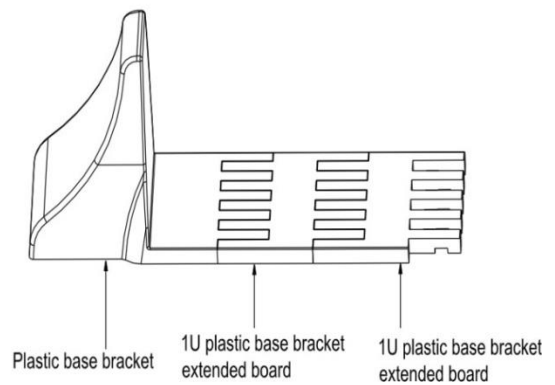
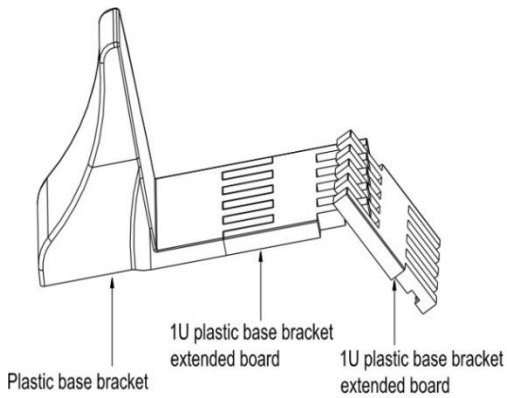

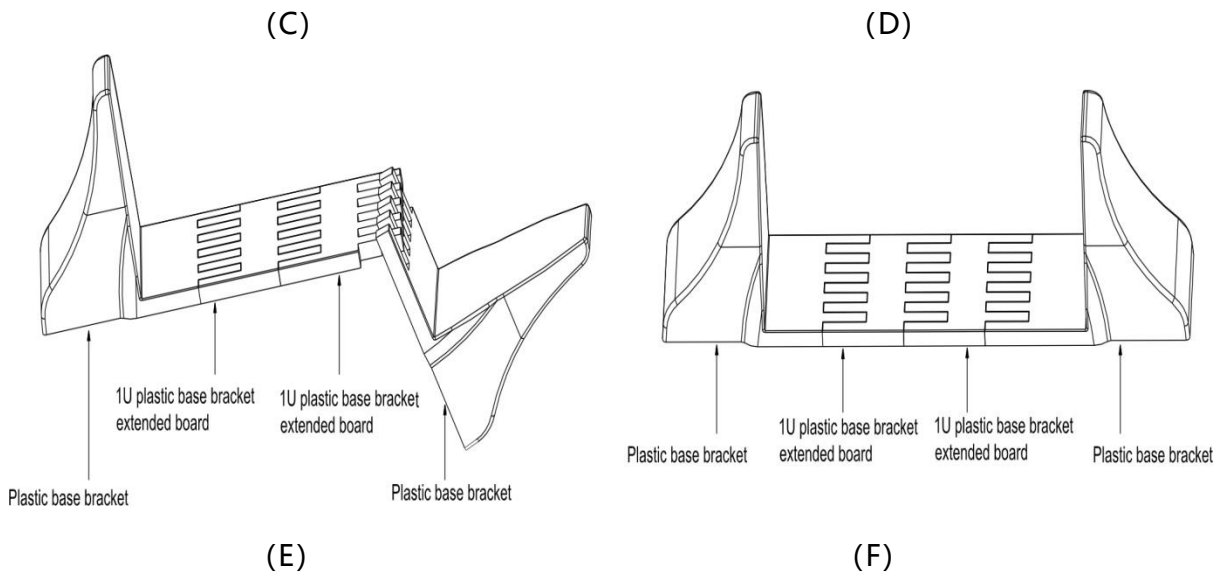

Figure 3.7 Plastic Base Extension

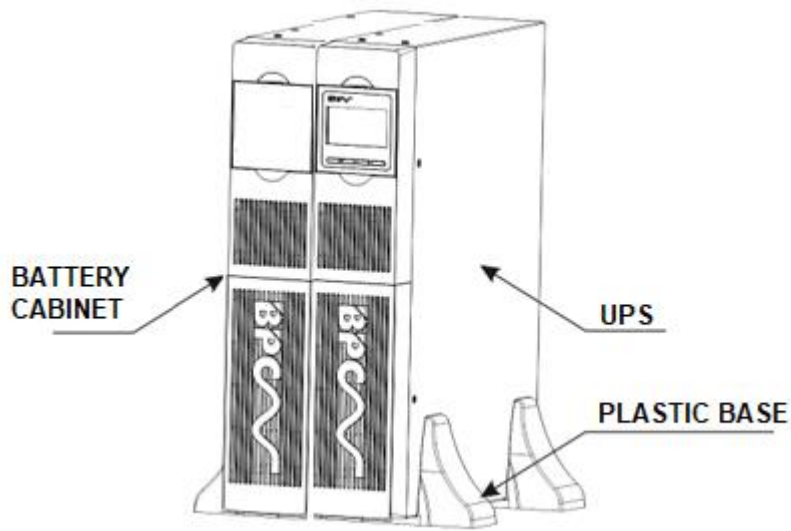

Figure 3.8 Completed Assembly

### 3.3.7 INTERNAL BATTERY CONNECTION

NOTE: All UPS ARE SUPPLIED WITH INTERNAL BATTERY DISCONNECTED

Remove the front cover of each UPS, Press the cover side with LCD display, hold the other side and quickly extract it, then extract the other side with display. (see Fig.3.8)



Figure3.8 Removing front facia – Display side first



**WARNING:** A small amount of arcing may occur when connecting the internal batteries. This is normal and will not harm personnel. Connect the cables quickly and firmly

Locate the battery connector and plug into the battery socket.



Figure3.9 Battery internal Anderson connector

### 3.3.8 EXTERNAL BATTERY CONNECTION



**WARNING:** A small amount of arcing may occur when connecting the internal batteries. This is normal and will not harm personnel. Connect the cables quickly and firmly

The Extendable battery cabinets (EBC) connect together with provided cables as per Figure 3.10. All connections are at the rear of the cabinet. Each EBC is fitted with two connections and either connection can be used.

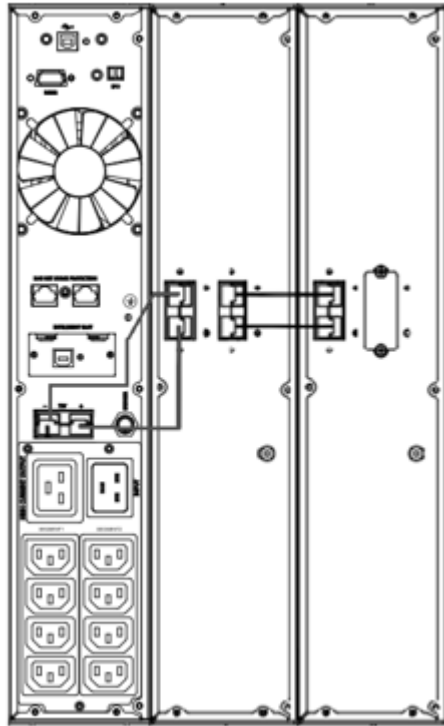

Figure3.10 Battery External Anderson connector

A separate cable is provided with the UPS to connect stand alone battery cabinets as seen in Figure 3.11

It is advised to always install a DC Fuse between the battery and UPS for protection.

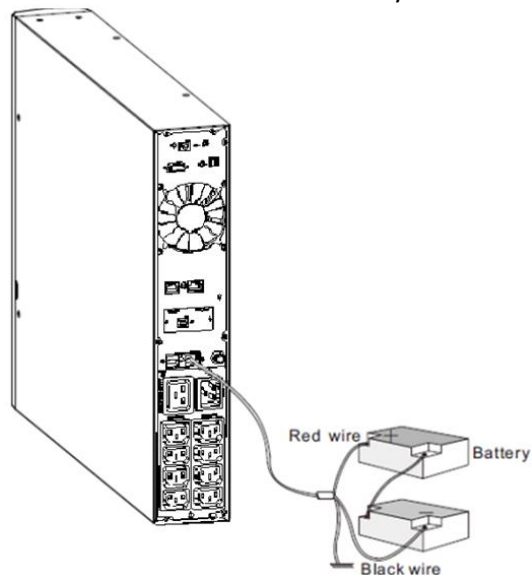

Figure3.11 Battery Connection to stand alone battery



## CHAPTER 4 – EXTENDABLE BATTERY CABINETS

Extendable Battery Cabinets (EBC) can be installed to increase the operational runtime of the UPS during a mains failure.

It is important to check the charge current of the standard system and for the Long runtime UPS version to ensure batteries can be recharged in the required duration.



**CAUTION:** It is advised to only connect a maximum of 1 EBC to standard UPS models, if more EBC are to be used then a L version UPS should be used

As each of the UPS systems variants 1-3kVA operate at different DC voltages, it is important to check the supplied EBC is compatible with the supplied UPS.



**CAUTION:** Always check the rating plate of the UPS and battery cabinet to ensure DC Nominal voltage is the same.

MODEL	PGPRT1000V2 (L)	PGPRT2000V2 (L)	PGPRT3000V2 (L)
<b>BATTERY</b>			
Battery Type	VRLA AGM Sealed Lead Acid Maintenance Free Batteries		
Numbers	2 or 3	4	6
Backup time	Long run unit depends on the capacity of external batteries		
Typical recharge time (standard model)	4 hours recover to 90% capacity (Typical)		
Charging voltage	27.4 ±1% or 40.9 ±1%	54 ±1%	109.4±1%
Charge current	1A Standard / 12A Adjustable for L Version		

MODEL	BCRT04N009	BCRT06N009	BCRT08N009
<b>Battery Type</b>	VRLA Sealed Lead Acid Battery		
<b>Battery Numbers</b>	4 blocks	6 blocks	8 blocks
<b>Battery Voltage</b>	24VDC	36VDC	24VDC or 48VDC
<b>Expected Battery Life</b>	3-5 years	3-5 years	3-5 years
<b>Battery Amp-Hour Capacity</b>	18Ah	18Ah	36Ah or 18Ah
<b>Dimensions – width X depth x height mm</b>	88 x 430 x 438	88 x 435 x 438	88 x 552 x 438
<b>Net Weight</b>	17.4kgs	22.2kgs	28.5kgs
<b>Recommended Operating Environment</b>	20°C		
<b>UPS Compatibility</b>	PGPRT 1000VA UPS	PGPRT 1000VA UPS	PGPRT 1000VA UPS PGPRT 2000VA UPS



MODEL	BCRT12N009	BCRT15N009	BCRT16N009
<b>Battery Type</b>	VRLA Sealed Lead Acid Battery		
<b>Battery Numbers</b>	2 X 6 blocks	5 X 3 blocks	4 X 4 blocks
<b>Battery Voltage</b>	72VDC	36VDC	48VDC
<b>Expected Battery Life</b>	3-5 years	3-5 years	3-5 years
<b>Battery Amp-Hour Capacity</b>	18Ah	45Ah	36Ah
<b>Dimensions – width X depth x height mm</b>	88 x 720 x 438	133 x 585 x 438	133 x 585 x 438
<b>Net Weight</b>	41.1kgs	53.5kgs	56kgs
<b>Recommended Operating Environment</b>	20°C		
<b>UPS Compatibility</b>	PGPRT 3000VA UPS	PGPRT 1000VA L Version	PGPRT 2000VA L Version

## CHAPTER 5 – OPERATION INSTRUCTIONS

### 5.1 START UP

*Note: When you turn on the PGPRT system its initial operating mode depends on the working conditions that were present when the system was previously shut down. This procedure covers the complete sequence of actions required to turn on the system from a fully powered-down state and then select the wanted operating mode.*



**WARNING:** PGPRT should never be operated without neutral connection.

#### 5.1.1 START UP UPS FROM MAINS

1. Turn on the input mains supply:
2. Once mains power is plugged in, the UPS will begin to charge the battery, the LCD shows that the output voltage is 230, which means the UPS automatically started to bypass mode.
3. Press and hold the ON key for more than three seconds to start the UPS, then it will start the inverter.
4. Once started, the UPS will perform a self-test function, LED will light on and go out repeatedly. When the self-test finishes, it will transfer to line mode, the corresponding LED lights will show the UPS is working in line mode.

#### 5.1.2 START UP UPS FROM BATTERY

1. When mains power is disconnected, press and hold the ON key for more than half a second to start UPS.
2. Once started, the UPS will perform a self-test function, LED will light on and go out repeatedly. When the self-test finishes, it will transfer to line mode, the corresponding LED lights will show the UPS is working in line mode.
3. The UPS will beep to show its operating from battery.

#### 5.1.3 SHUTDOWN OPERATION





**WARNING:** IF “BYPASS ENABLE/DISABLE SETTING” Is set to OFF, pressing the OFF button will result in loss of output power.



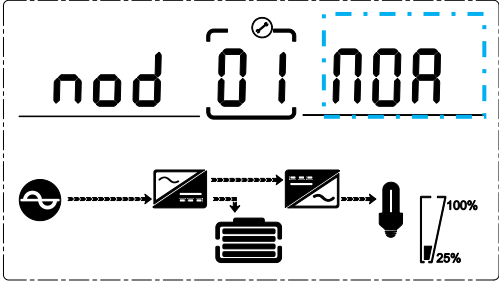
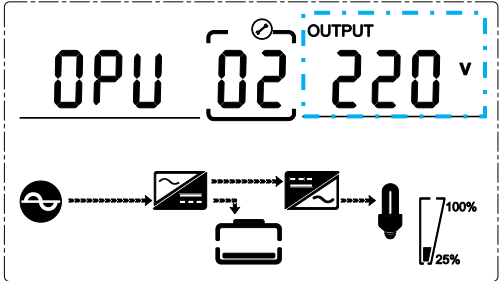

1. Press and hold the OFF key for more than half a second to turn off the UPS and inverter.
2. The UPS will transfer to bypass
3. Disconnect the incoming supply
4. After the UPS shutdown, the LEDs go out and there is no output.

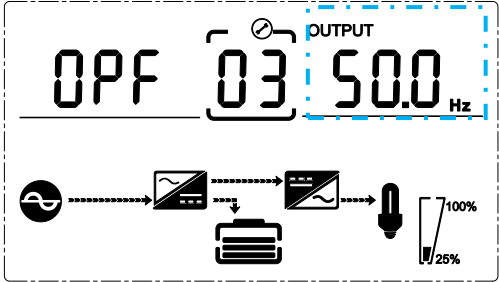
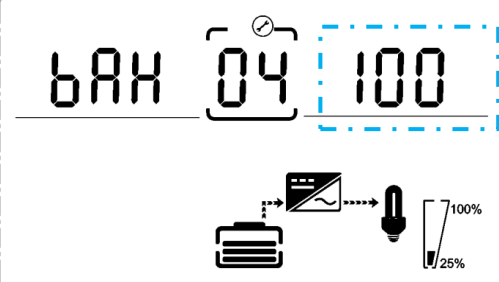
## CHAPTER 6 – SETTINGS INSTRUCTIONS

### 6.1 START UP

ITEM	SETTINGS	CONTENT DISPLAY
01	<p style="text-align: center;"><b>MODE SETTING</b></p> <p>Press Enter button to change the setting (ECO or NOR or CF or GEN).</p> <p>ECO – System operates in bypass in normal operation – If the Input voltage is above or below the bypass voltage range the UPS will transfer to battery.</p> <p>NOR – Normal Double conversion protection mode</p> <p>CF – System operates as a frequency converter – dependant on output frequency setting e.g. if input is 50Hz and output of 60Hz is required, this setting should be applied. Bypass is disabled.</p> <p>GEN – Generator mode – As the voltage and frequency of the generator can fluctuate, the operating range of the input will set at 110-300V and 40-70Hz</p> <p>Press UP ▲ button to select the previous setting.</p> <p>Press DOWN ▼ button to select the next setting.</p>	
02	<p style="text-align: center;"><b>OUTPUT VOLTAGE SETTING</b></p> <p>Press Enter button to change the Inverter fixed output voltage setting (208,220,230,240).</p> <p>Press UP ▲ button to select the previous setting.</p> <p>Press DOWN ▼ button to select the next setting.</p>	

<p>03</p>	<p><b>FREQUENCY SETTING</b></p> <p>Press Enter button to change the output frequency setting (50 or 60Hz).</p> <p>Press UP button ▲ to select the previous setting.</p> <p>Press DOWN button ▼ to select the next setting.</p>	
<p>04</p>	<p><b>BATTERY CAPACITY SETTING</b></p> <p>Press Enter button to change the setting (Battery capacity range is 1-200Ah).</p> <p>If 1 x 3kva has 1 x 6 x 9Ah batteries installed this value should read 9Ah</p> <p>If 1 x 3kva has 1 x 6 x 9Ah batteries installed. And 1 battery cabinet with 2 x 6 x 9Ah installed. This value should read 3 x 9Ah = 27Ah</p> <p>NOTE this is required to provide accurate runtimes on display.</p> <p>Press UP button ▲ to select the previous setting.</p> <p>Press DOWN button ▼ to select the next setting.</p>	
<p>05</p>	<p><b>BATTERY EOD VOLTAGE SETTING (PRIMARY)</b></p> <p>The battery voltage setting at which the UPS turns off during mains failure. E.g. 6 cells per block x 1.75 x 6 battery blocks per string = 63Vdc. During discharge when the battery voltages reaches 63Vdc the UPS will turn off.</p> <p>Press Enter button to change the setting (1.60/1.70/1.75/1.80).</p> <p>Press UP button ▲ to select the previous setting.</p>	

	<p>Press DOWN button ▼ to select the next setting.</p>	
06	<p><b>BATTERY EOD VOLTAGE SETTING (SECOND)</b></p> <p>NOTE: Only used if optional second set of terminals installed during manufacture (not fitted as standard). Press Enter button to change the setting (1.60/1.70/1.75/1.80).</p> <p>Press UP button ▲ to select the previous setting.</p> <p>Press DOWN button ▼ to select the next setting.</p>	
07	<p><b>BYPASS VOLTAGE UPPER LIMIT SETTING</b></p> <p>Press Enter button to change the setting (The bypass voltage upper limit range is 230-264Vac ).</p> <p>Press UP button ▲ to select the previous setting.</p> <p>Press DOWN button ▼ to select the next setting.</p>	
08	<p><b>BYPASS VOLTAGE LOWER LIMIT SETTING</b></p> <p>Press Enter button to change the setting (The bypass voltage lower limit range is 176-220Vac).</p> <p>Press UP button to select the previous setting.</p> <p>Press DOWN button to select the next setting.</p>	
09	<p><b>MUTE SETTING</b></p> <p>Press Enter button to change the setting (ON or OFF).</p> <p>Press UP button to select the previous setting.</p> <p>Press DOWN button to save and exit the setup.</p>	

10	<p><b>BYPASS ENABLE/DISABLE SETTING</b></p> <p>Enable – When the OFF button is pressed on the display the system will transfer to internal bypass.</p> <p>Disable – When the OFF button is pressed on the display the system turns off the output completely.</p> <p>Press Enter button to change the setting (ON or OFF).</p> <p>Press UP button ▲ to select the previous setting.</p> <p>Press DOWN button ▼ to save and exit the setup.</p>	
----	--	--

## CHAPTER 7 – MAINTENANCE INSTRUCTIONS

The PGPRT does not contain any user-serviceable parts, however the UPS contains life-limited components (Capacitors and Fans) that require replacement at regular intervals, so that day-to-day maintenance requirements are kept to a minimum, aside from ensuring that the operating environment is kept cool and dust free, we recommend that the UPS and batteries are inspected and calibrated on a 12 monthly basis (6 months depending on environment) as part of a preventative maintenance schedule to maximise the system's performance, working life and reliability. A clean operating environment will help maximise the useful working life and reliability of both the PGPRT and its batteries.

### 7.1 Preventative maintenance inspection

Preventative maintenance inspections form an integral part of all Extended Warranty Agreements (maintenance contracts) offered by BPC Energy Ltd.

During a preventative maintenance inspection, the engineer will check and validate:

- Site environmental conditions
- Integrity of electrical installation
- Cooling airflow
- Load characteristics
- Integrity of alarm and monitoring systems
- Operation of all installed options.

### 7.2 Battery maintenance and testing

The battery installation should be inspected on a regular basis, not exceeding 12-months.

Traditional VLR battery testing and maintenance consists of:

- Checking and recording the open-circuit battery voltage
- Verifying that the float charging voltage is correct
- Inspecting all battery terminals and connections for corrosion
- Inspecting all batteries for cracks, leaks or swelling
- Checking the integrity of the inter-cell connections
- Removing any materials and cleaning around the equipment
- Carry out a full battery check.

## CHAPTER 8 – TROUBLE SHOOTING

The PGPRT will generate an audible warning if a fault or abnormal operating condition is detected and will indicate the source of the triggered alarm on the LCD panel.

There are no user-serviceable parts in the PGPRT cabinet, so the degree of rectification that can be carried out by the operator is minimal.

Ensure that the system's AC and DC power supplies are available and within specification, and the load connected to the UPS OUTPUT is within the cabinet rating.

An internal fault can usually be attributed to a faulty PCB, control panel or an ancillary assembly such as the cooling fan, all of which require the attention of a trained engineer who will exchange the faulty assembly in most instances.

## 8.1 ALARMS AND WARNING MESSAGES

EVENT LOG	UPS ALARM WARNING	BUZZER	LED
1	Rectifier Fault	Beep continuously	Fault LED lit
2	Inverter fault(Including Inverter bridge is shorted)	Beep continuously	Fault LED lit
9	Fan fault	Beep continuously	Fault LED lit
12	Self test fault	Beep continuously	Fault LED lit
13	Battery Charger fault	Beep continuously	Fault LED lit
15	DC Bus over voltage	Beep continuously	Fault LED lit
16	DC Bus below voltage	Beep continuously	Fault LED lit
17	DC bus unbalance	Beep continuously	Fault LED lit
18	Soft start failed	Beep continuously	Fault LED lit
19	Rectification model Over Temperature	Twice per second	Fault LED lit
20	Inverter model Over Temperature	Twice per second	Fault LED lit
26	Battery over voltage	Once per second	Fault LED blinking
27	Mains Input reverse	Once per second	Fault LED blinking
28	Bypass Input reverse	Once per second	Fault LED blinking
29	Output Short-circuit	Once per second	Fault LED blinking
30	Input current limit	Once per second	Fault LED blinking
31	Bypass over current	Once per second	BPS LED blinking
32	Overload	Once per second	INV or BPS LED blinking
33	No battery	Once per second	Battery LED blinking
34	Battery under voltage	Once per second	Battery LED blinking
35	Battery low pre-warning	Once per second	Battery LED blinking
36	Overload time out	Once per 2 seconds	Fault LED blinking
37	DC component over limit.	Once per 2 seconds	INV LED blinking
39	Mains volt. Abnormal	Once per 2 seconds	Battery LED lit
40	Mains freq. abnormal	Once per 2 seconds	Battery LED lit
41	Bypass Not Available		BPS LED blinking
42	Bypass out of tracking range		BPS LED blinking
45	EPO Enable	Beep continuously	Fault LED lit



## 8.2 POSSIBLE CAUSE

SYMPTOM	POSSIBLE CAUSE	SOLUTION
No indication and alarm even though the mains is normal.	The AC input power is not connected well.	Check if input power cord firmly connected to the mains.
	The AC input is connected to the UPS output.	Plug AC input power cord to AC input correctly.
Alarm code is shown as "33" and battery led blinking.	The external or internal battery is incorrectly connected.	Check if all batteries are connected well.
Alarm code is shown as "26" and battery led blinking.	Battery voltage is too high, or the charger is faulty.	Contact your dealer.
Alarm code is shown as "34" and battery led blinking	Battery voltage is too low, or the charger is faulty.	Contact your dealer.
Alarm code is shown as "32" and INV or BYPASS led blinking.	UPS is overload	Remove excess loads from UPS output.
Alarm code is shown as "27&28" and FAULT led light.	Mains Input reverse & Bypass Input reverse	Check input L/N wiring Reverse connection
Alarm code is shown as "29" and FAULT led light.	The UPS shut down automatically because short circuit occurs on the UPS output.	Check output wiring and if connected devices are in short circuit status.
Alarm code is shown as "9" and FAULT led light.	Fan fault.	Contact your dealer.
Alarm code is shown as "01,02, 15,16,17,18"	A UPS internal fault has occurred.	Contact your dealer.
Battery backup time is shorter than nominal value	Batteries are not fully charged	Charge the batteries for at least 5 hours and then check capacity. If the problem still persists, consult your dealer.
	Batteries defect	Contact your dealer to replace the battery.

## CHAPTER 9 – COMMUNICATION

### 9.1 INTRODUCTION

The following external connections are available for EL300DSP Series EL INVERTERS.

- USB Port.
- RS232 Port.
- Intelligent Slot.
- EPO

**USB port**



**RS-232 port**

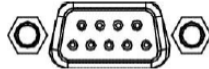

**Intelligent slot**

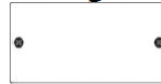

Using one of the above communication options is satisfactory for remote monitoring and control in most of the systems. But some systems may use 2 or 3 of the above options at the same time. In this case the accessories group produced by BPC may help to make appropriate solutions.

### 9.2 USB Port

Monitoring Software is provided on CD within the packaging and is also available for download from BPC Website

### 9.3 INTELLIGENT CARD SLOT

#### 9.3.1 SNMP - OPTIONAL

Simple Network Management Protocol (SNMP) is a world-wide, standardised communication protocol that can be used to monitor any network-connected device via a simple control language and display the results in an application running within a standard web browser.

An SNMP card slot, designed to house a Modem/Ethernet SNMP adapter card, is located behind a cover plate on the right-hand side of the control panel. To fit the card, you must remove the cover plate, insert the card into its connector then secure it in place using the screws that you removed when taking off the cover plate.

The SNMP adapter card contains an RJ-45 Ethernet connector which allows the PGPRT to be connected to a network using a standard CAT-5 network cable. Once connected, the system management software agent that is preinstalled in the SNMP adapter monitors the PGPRT operation and outputs its data in SNMP format to the connected network.

The communication exchanged between the PGPRT and network enables event/alarm emails, server shut down (with optional licenses) and other tasks to be performed. It can also be integrated with BMS software over a local area network (LAN) for SNMP.

The SNMP adaptor requires a PC with terminal connections, and for normal operation at least one Ethernet connection.

*Note: SNMP connectivity can also be implemented using an external SNMP adapter connected to the RS232 output.*

### 9.3.2 RELAY – DRY PORT - OPTIONAL

A mini dry contact card is used for providing the interface for UPS peripheral monitoring. The contact signals can reflect UPS running status. The card is connected to peripheral monitoring devices via a terminal board to facilitate the effective monitoring of the real-time status of UPS and timely feedback the status to monitor when an abnormal situation occurs ( such as UPS failure, mains interruption, UPS bypass, etc). It is installed in the intelligent slot of the UPS.

The relay card includes 6 output ports and one input port. Please refer to the following table for further details.



Terminal No.	Terminal function	Terminal No.	Terminal function
1	Common source	9	Bypass active NO
2	UPS on NO	10	Bypass active NC
3	AC fail NO	11	UPS fail NO
4	AC fail NC	12	UPS fail NC
5	Batt low NO	CN4-1	Remote shutdown
6	Batt low NC	CN4-2	GND
7	UPS alarm NO		
8	UPS alarm NC		

### 9.4 EPO EMERGENCY POWER OFF

EPO is used to shut down the UPS remotely.

When EPO is activated, the UPS shuts down the output and all its power converters immediately. The UPS remains on to indicate the present alarm.

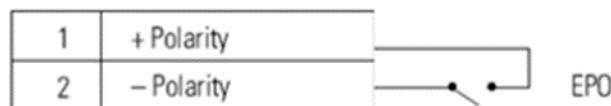

NOTE Depending on user configuration, the pins must be shorted or opened to keep the UPS running. To restart the UPS, reconnect (re-open) the EPO connector pins and turn on the UPS manually. Maximum resistance in the shorted loop is 10 ohms.

Always test the EPO function before applying your critical load to avoid accidental load loss. Leave the EPO connector installed onto the EPO port of the UPS even if the EPO function is not needed.

## CHAPTER 10 – TECHNICAL SPECIFICATION

MODEL	PGPRT1000V2 (L)	PGPRT2000V2 (L)	PGPRT3000V2 (L)
PHASE	Single phase with ground		
Capacity (VA/Watts)	1000VA/ 1000W	2000VA / 2000W	3000VA / 3000W
<b>INPUT</b>			
Nominal voltage	208/220/230/240VAC		
Operating voltage range (Ambient Temp. <40°C)	Low line transfer	176Vac±5% @100%-50% load; 110Vac±5% @50%-0% load;	
	Low line comeback	186Vac±5% @100%-50% load; 120Vac±5% @50%-0% load;;	
	High line transfer	264Vac±5% @100%-50% load; 300Vac±5% @50%-0% load;	
	High line comeback	254Vac±5% @100%-50% load; 290Vac±5% @50%-0% load;	
Operating frequency range**	40-70Hz		
Power factor	0.99@100% load(Nominal Input Voltage)		
Bypass voltage range	Bypass high voltage point 230-264: setting the high voltage point in LCD from 230Vac to 264Vac. (Default: 264Vac) Bypass low voltage point 176-220: setting the low voltage point in LCD from 176Vac to 220Vac. (Default: 176Vac)		
Generator input	Support		
<b>OUTPUT</b>			
Output voltage*	208/220/230/240Vac		
Power factor	0.8/0.9/1.0		
Voltage regulation	±1%		
Frequency	Line Mode (synchroni zed range)	46-54Hz or 56-64Hz	
	Bat. Mode	(50/60±0.1)Hz	
Crest factor	3:1		
Harmonic distortion (THDv)	≤3% THDwith linear load ≤5% THD with non linear load		
Waveform	Pure Sinewave		
Transfer time	AC mode <->Batt. mode	Zero	
	Inverter <-> bypass	4ms(Typical)	
Efficiency	90% (AC mode) 86%(DC mode)	91%(AC mode) 87%(DC mode)	91%(AC mode) 88%(DC mode)

MODEL		PGPRT1000V2 (L)	PGPRT2000V2 (L)	PGPRT3000V2 (L)
<b>BATTERY</b>				
Battery type		VRLA AGM Sealed Lead Acid Maintenance Free Batteries		
Numbers		2 or 3	4	6
Backup time		Long run unit depends on the capacity of external batteries		
Typical recharge time (standard model)		4 hours recover to 90% capacity (Typical)		
Charging voltage		27.4 ±1% or 40.9 ±1%	54 ±1%	109.4±1%
Charge current		1A Standard / 12A Adjustable for L Version		
<b>SYSTEM FEATURES</b>				
Overload	Line Mode	105%~125%: UPS transfer to bypass after 1 minute when the utility is normal 125%~130%: UPS transfer to bypass after 30 seconds when the utility is normal >130%: UPS transfer to bypass immediately when the utility is normal		
	Batt. Mode	105%~125%: UPS after 1 minute shut down; 125%~130%: UPS after 10 seconds shut down; >130%: UPS immediately shut down;		
Short circuit		Hold Whole System		
Over temperature		Line Mode: Switch to Bypass; Backup Mode: Shut down UPS immediately		
Low battery voltage		Alarm and Switch off		
EPO (optional)		Shut down UPS immediately		
Audible & Visual alarms		Line Failure, Battery Low, Overload, System Fault		
Communication interface		USB (or RS232), SNMP card (optional), Relay card (optional)		
<b>ENVIRONMENTAL</b>				
Operating temperature		0°C~40°C		
Storage temperature		-25°C~55°C		
Humidity range		20-90 % RH @ 0- 40°C (non-condensing)		
Altitude		< 1500m		
Noise level		Less than 55dBA at 1 Meter		
<b>PHYSICAL</b>				
Dimension WxDxH (mm)		24VDC 440*325*88 36VDC 440*460*88 (L) 440*325*88	440*460*88 (L) 440*600*88	440*600*88 (L) 440*600*88
Net Weight (kg)		11.3 (L 5.6)	19.5 (L 8.5)	26.2 (L 8.8)
<b>STANDARDS</b>				
Safety		IEC/EN62040-1, IEC/EN60950-1		
EMC		IEC/EN62040-2, IEC61000-4-2, IEC61000-4-3, IEC61000-4-4, IEC61000-4-5, IEC61000-4-6, IEC61000-4-8		

\* Derate to 80% of capacity when the output voltage is adjusted to 208VAC

\*\* Derate to 75% of capacity when the Input voltage frequency is out of range (50/60±4Hz)

\*\*\* Product specifications are subject to change without further notice.