



The British *Power Conversion* Company

**BPC083-10
POWER PRO EL 300DSP – 10-60KVA
USER MANUAL**



CONTENTS

CHAPTER 1 – SAFETY WARNINGS.....	4
1.1 DESCRIPTION OF SYMBOLS USED IN THIS MANUAL.....	4
1.2 GENERAL WARNINGS.....	4
1.3 BATTERY SAFETY	5
CHAPTER 2 – GENERAL DESCRIPTION.....	6
2.1 INTRODUCTION.....	6
2.2 FUNCTIONAL DESCRIPTION.....	8
2.3 MODES OF OPERATION.....	9
2.3 COMPONENT DESCRIPTION	11
2.3.1 CABINET	11
2.3.2 CONTROL DISPLAY.....	14
2.3.4 DISPLAY SUB MENU	14
2.3.5 MEASUREMENTS MENU	16
2.3.6 ALARMS LOG MENU.....	20
2.3.7 INFORMATION MENU	20
2.3.8 OPTIONS MENU	21
2.3.8 COMMAND MENU	24
2.3.8 TIME MENU.....	25
2.3.8 SERVICE MENU	26
2.3.8 ADJUST MENU.....	26
2.3.8 USER PASSWORD	26
CHAPTER 3 – INSTALLATION	27
3.1 INTRODUCTION.....	27
3.2 ACCEPTING DELIVERY.....	27
3.2.1 REPORTING DAMAGE.....	27
3.2.2 STORAGE	27
3.2.3 UNPACKING INSTRUCTIONS.....	28
3.3 INSTALLATION	28
3.3.1 ENVIRONMENTAL CONSIDERATIONS.....	28
3.3.2 CLEARANCES.....	29
3.3.4 CABLE CONSIDERATIONS	29
3.3.5 INRUSH CURRENT.....	30

3.3.6 CABLE SPECIFICATION	31
3.3.7 ELECTRICAL PLANNING	31
3.3.8 CABLINING PROCEDURE.....	31
3.3.8.1 SAFETY NOTES.....	31
3.3.8.2 TERMINAL CONNECTIONS.....	32
CHAPTER 4 – OPERATION INSTRUCTIONS	34
4.1 START UP.....	34
4.2 SHUT DOWN.....	34
4.3 CHANGEOVER MODE TO INVERTER MODE	34
CHAPTER 5 – MAINTENANCE INSTRUCTIONS	35
5.1 EMERGENCY LIGHTING MAINTENANCE.....	35
5.2 SCHEDULED MAINTENANCE	35
CHAPTER 6 – TROUBLE SHOOTING	36
6.1 ALARMS AND WARNING MESSAGES	36
2.3.8 STATUS CODES	38
6.2 ALARM MESSAGES AND TROUBLESHOOTING	45
CHAPTER 7 – COMMUNICATION	51
7.1 INTRODUCTION.....	51
7.2 SERIAL PORT CONNECTION.....	51
7.3 DRY CONTACT CONNECTIONS.....	52
7.3.1 CONTROLS.....	52
7.3.2 DRY PORT CONTACTS.....	53
7.3.4 SNMP CARD SLOT.....	54
CHAPTER 8 – TECHNICAL SPECIFICATION	55
8.1 GENERAL SPECIFICATIONS	55
8.2 RECTIFIER SPECIFICATIONS	55
8.3 BATTERY SPECIFICATIONS.....	56
8.4 INVERTER SPECIFICATIONS	56
8.5 BYPASS SPECIFICATIONS	57
8.6 OPTIONAL SPECIFICATIONS.....	57
8.7 MECHANICAL SPECIFICATIONS	57

CHAPTER 1 – SAFETY WARNINGS

Read the following safety information carefully before you install or operate the BPC PowerPro EL 300DSP Static Inverter (SI) equipment and keep this manual within easy access of the equipment for future reference.

1.1 DESCRIPTION OF SYMBOLS USED IN THIS MANUAL



WARNING: The warning symbol is used where there is danger of an electrical shock, equipment damage or personal injury.



CAUTION: The caution symbol is used to highlight important information to avoid possible equipment malfunction or damage.

1.2 GENERAL WARNINGS



WARNING: Be aware that the output from this equipment can be energized when the unit is not connected to a mains supply, even when the input AC power is disconnected



WARNING: The PowerPro EL 300DSP assembly and peripheral equipment must be installed and commissioned by suitably qualified and trained personnel who are aware of the potential shock hazards.



WARNING: The PowerPro EL 300DSP must be supplied by a grounded outlet. Do not operate the unit without a ground source.



WARNING: To reduce the risk of electric shock:

- Do not insert any object into ventilation holes or other openings
- Do not remove any equipment cover – the unit does not contain any user-serviceable parts. Refer all servicing requirements to qualified service personnel.
- Always disconnect the PowerPro EL 300DSP from the mains power supply before you install a computer interface signal cable. Reconnect the power only after the signalling interface connections have been made.



WARNING: To reduce the risk of fire:

- Install this equipment in a temperature and humidity controlled indoor area free of conductive contaminants.
- If a fuse ruptures always replace it with a fuse of the same type and rating.

1.3 BATTERY SAFETY



WARNING: The battery is not isolated from the mains voltage. Hazardous voltage may occur between the battery terminals and ground.



WARNING: A battery can present a risk of electric shock or burn from high short circuit currents. Always take the following precautions when working on batteries:

- Remove watches, rings or other metal objects.
- Use tools with insulated handles.



WARNING: The PowerPro EL 300DSP system uses recyclable batteries:

- The batteries contain lead and pose a hazard to the environment and human health if not disposed of properly.
- If you replace the batteries you must dispose of the used batteries in accordance with local environmental laws and regulations.



WARNING: Heed the following warnings concerning battery handling:

- Do not dispose of batteries in a fire. The batteries may explode.
- Do not open or mutilate the batteries. They contain an electrolyte which is toxic and harmful to the skin and eyes.
- If electrolyte comes into contact with the skin, the affected area should be washed immediately with clean flowing water.
- The internal energy source (the battery) cannot be de-energized by the user.



WARNING: When changing the batteries, install the same number and same type of batteries.

CHAPTER 2 – GENERAL DESCRIPTION

2.1 INTRODUCTION

BPC EL300DSP Series Emergency Lighting (EL) Inverters are double conversion; Changeover / Inverter EL INVERTER's manufactured with the latest IGBT and PWM technology, to produce pure sine wave output to the lighting loads.

BPC EL300DSP Series units are 3-phase in/3-phase out devices, and they are installed between a three-phase lighting load, and a 3-phase+N mains supply.

The advantages of using EL300DSP EL INVERTER:

Power blackout protection:

If the mains power fails, the EL INVERTER continues to supply the critical load using the energy stored in its batteries, keeping the load immune from power disturbances.

Increased power quality:

The EL INVERTER has its own internal voltage and frequency regulating software, which ensures that its output to the critical load is maintained within close tolerances, independent of voltage and frequency variations on the mains power lines.

Fully digital control by three DSP controller for each EL INVERTER:

The EL INVERTER is controlled by 3 independent DSP chips which are communicating with each other continuously. Rectifier, Inverter and User Interface modules have separate DSPs to achieve the highest performance. Each DSP module has many parameters to control and monitor the system to have the best electrical power output and to help diagnostic.

Increased noise rejection:

By rectifying the input AC power to DC power and then converting it back to AC (Double-Conversion) any electrical noise present on the input mains supply line is effectively isolated from the EL INVERTER output. Therefore, the critical load is supplied with only clean and uninterrupted AC power.

Key features

- PWM and IGBT technology
- Pure sinusoidal output wave form and true on-line topology
- High input power factor (IGBT rectifier), Input current limiting
- Low input current THD (IGBT rectifier)
- Low output voltage THD
- High AC/AC and DC/AC efficiency (up to 94%)
- High charger capacity
- 3 separate DSP (Digital Signal Processor) control
- Cold-start feature
- Static By-Pass
- Bypass leakage current sense system
- Maintenance bypass switch and warning system, by-pass short circuit protection
- LCD alphanumeric display panel providing battery, load, voltage, power and status information in detail to user.

- Improved diagnostics and correct fault information
- Up to 192 event memory record system (7000 alarms or warnings total)
- Real time clock and calendar system
- Overload operation continuous at 100%-120% load, 10 minutes at 120%-150% load, 1 minute at 150%-180% load
- Output overload, over-current and short circuit protection, output current limiting
- Reliable operation at even 100% unbalanced load condition
- Non-linear load supply feature (CF 3:1)
- Double polarity battery (with common terminal)
- Automatic and manual battery test and battery temperature compensation features
- 3 separate maintenance clock counters
- Battery charge with current limiting
- Automatic and manual boost charge feature
- Battery deep discharge protection
- Temperature protection with 3 separate sensors
- Charger output short circuit protection
- Interactive communication
- Diagnostic and settings with PC ability
- 10 dry contact alarm relay outputs as standard (Digital/Contact inputs of EL control)
- AT command set definitions for dump modems
- Emergency power-off support
- Conformity to international and local standards
- AC input and output filters
- CE compliance
- Input, bypass and load phase order protection
- 2 separate RS232 communication ports (standard)

Optional features

- Multi EL INVERTER monitoring on same communication line by RS485 (optional)
- Improved remote monitoring panel system (optional)
- RS232 port multiplexer (optional)
- Direct network connection with optional SNMP support
- MODBUS Adapter (optional)
- Input and output isolation transformers (optional)
- Optional leakage current alarm system
- DC Earth leakage protection
- High IP rating
- Other voltage options

2.2 FUNCTIONAL DESCRIPTION

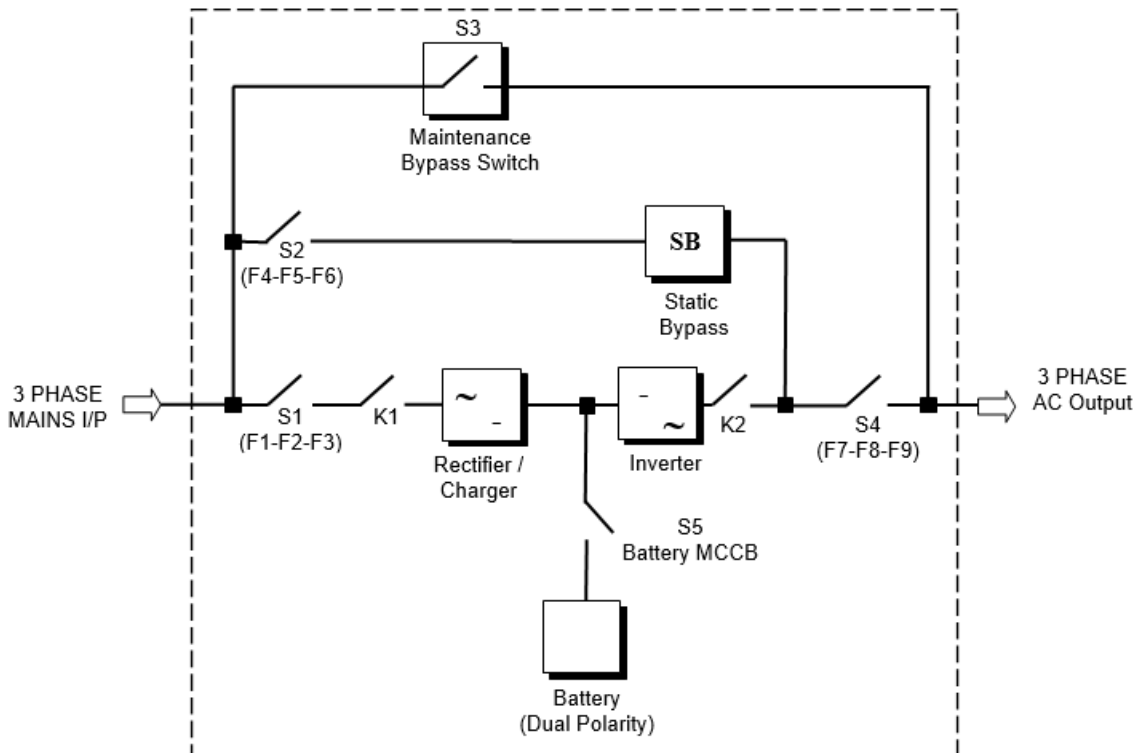

- S1 (F1-F2-F3)** : Rectifier Input Switch / Fuse
- S2 (F4-F5-F6)** : Bypass Input Switch / Fuse
- S3** : Maintenance Bypass Switch
- S4 (F7-F8-F9)** : Output Switch / Fuse
- S5** : Battery MCCB
- K1** : Rectifier Input Contactor
- K2** : Inverter Output Contactor

RECTIFIER: In EL 300DSP Series EL INVERTERS, a controlled IGBT rectifier with PWM technique is used to increase input power factor (PFC) and to decrease input current harmonics (THDI). The IGBT rectifier accepts AC input and produces a dual polarity DC voltage for both supplying the inverter and charging the batteries.

BATTERIES: Batteries are used as reserve DC power supply for the Inverter in case of mains failure. Batteries are connected in series with a centre-tap output to obtain a dual polarity DC supply. Batteries are discharged by the inverter during mains failure. The discharged batteries are re-charged by the IGBT Rectifier on a constant voltage / current limiting basis, if AC mains power is available.

INVERTER: It is manufactured by using the latest IGBT and DSP (Digital Signal Processing) technologies, and Pulse Width Modulation (PWM) technique. The Inverter converts the DC BUS voltage supplied by the IGBT Rectifier and / or the batteries into a well-regulated, fully digital controlled AC voltage with fixed voltage and frequency.

The output of the inverter is used to supply the critical loads connected to the EL INVERTER output.

STATIC TRANSFER SWITCH (STS): This is an electronically controlled transfer switch, which enables the critical load to be connected either to inverter output or to by-pass power source. During normal operation, the load is supplied by the inverter output, but in case of an overload or a EL INVERTER failure it is automatically transferred to the bypass source without any interruption.

2.3 MODES OF OPERATION

The PowerPro EL 300DSP can be configured to operate in one of three modes to suit the degree of supply integrity required for a particular lighting application.

Changeover mode

When operating in the 'changeover' mode the rectifier is turned on to provide battery charging. The inverter is turned on and operating on standby (off load) the bypass-side of the static switch is turned on to connect the SI OUPUT to the AC INPUT via the internal bypass line.

If the utility supply fails, the static switch will transfer the SI OUPUT to the inverter within 10ms. However, as the utility supply is in a failed state the rectifier is inoperative and the inverter will be powered solely from the batteries (see Figure 2.4).

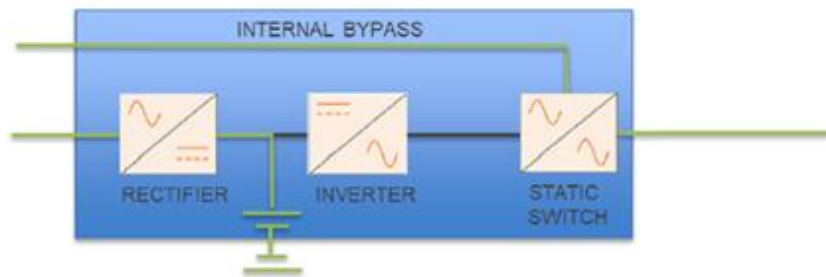

Figure 2.1

Inverter mode

When operating in the 'inverter' mode the rectifier is turned on to power the inverter and provide battery charging.

The inverter is turned on and the inverter-side of the static switch is turned on to connect inverter to the SI OUPUT.

The emergency luminaires are powered from the regulated inverter output.

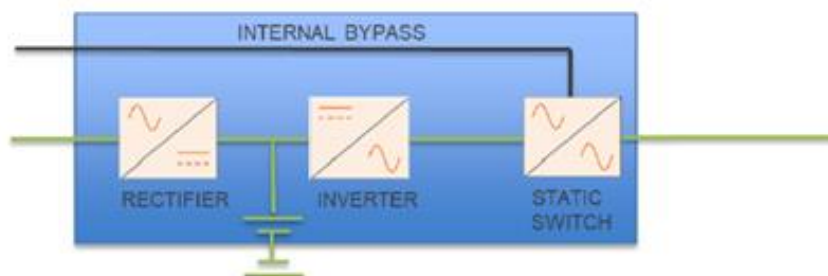

Figure 2.2

On battery operation

If the mains supply fails, the rectifier will turn off, but the inverter will continue to operate from battery power until the batteries reach their end-of-discharge voltage; at which point the inverter will shut down and disconnect the SI OUTPUT supply.

If the AC INPUT supply is restored before the batteries are fully discharged, the rectifier will turn on automatically to once again power the inverter and recharge the batteries.

The whole process of switching between rectifier and battery power is totally transparent to the emergency luminaires.

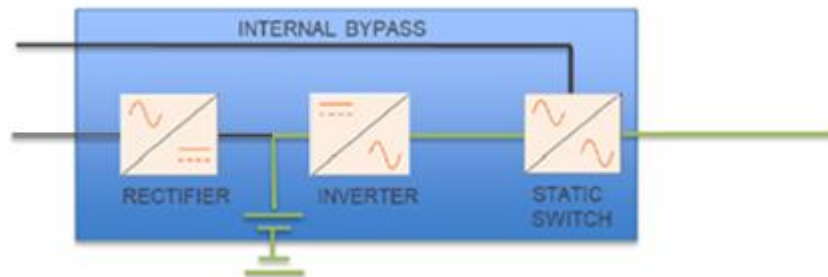

Figure 2.4

2.3 COMPONENT DESCRIPTION

2.3.1 CABINET

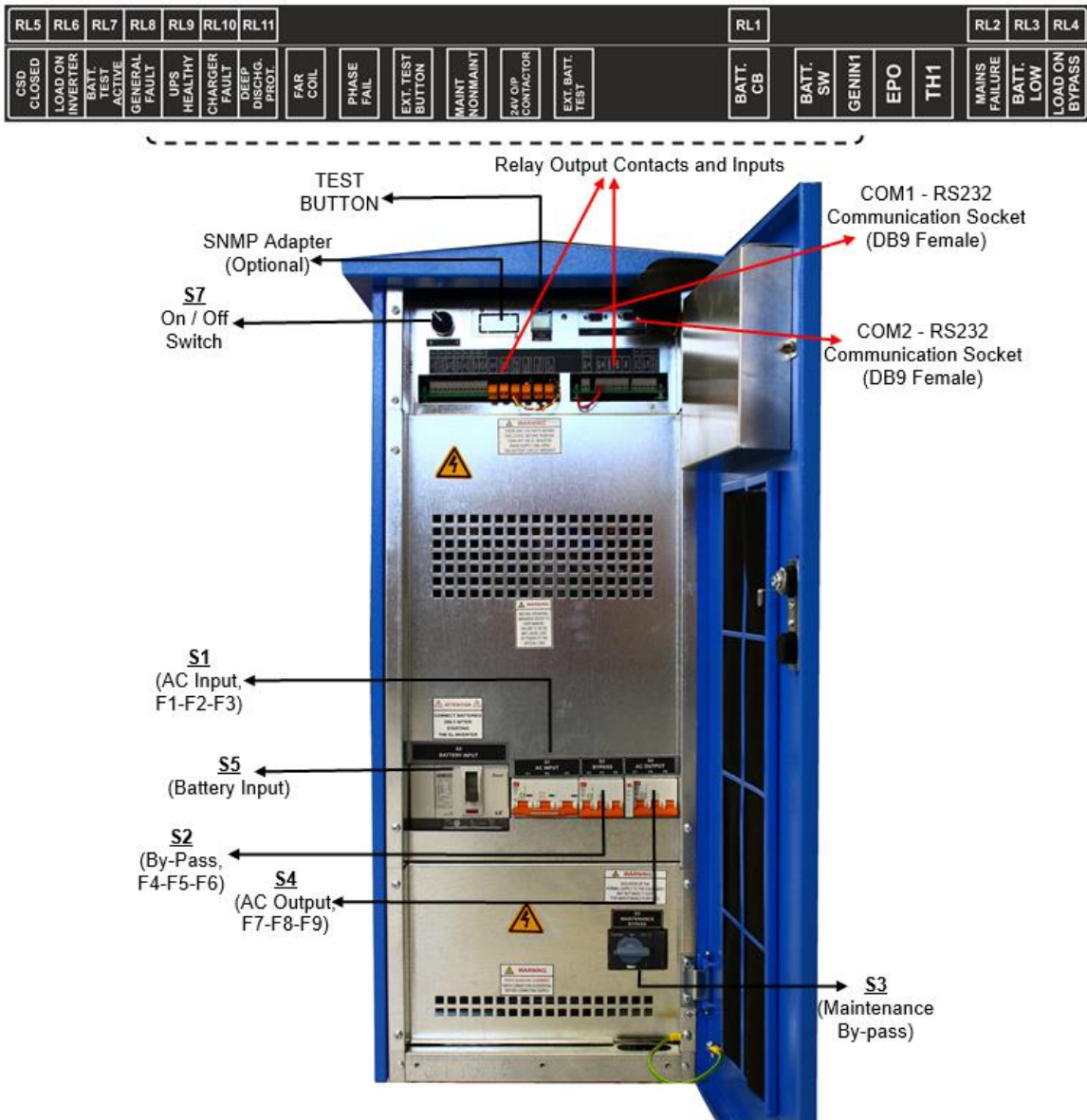

Figure 2.5A - 10-20 kVA Fuses and Switches Panel

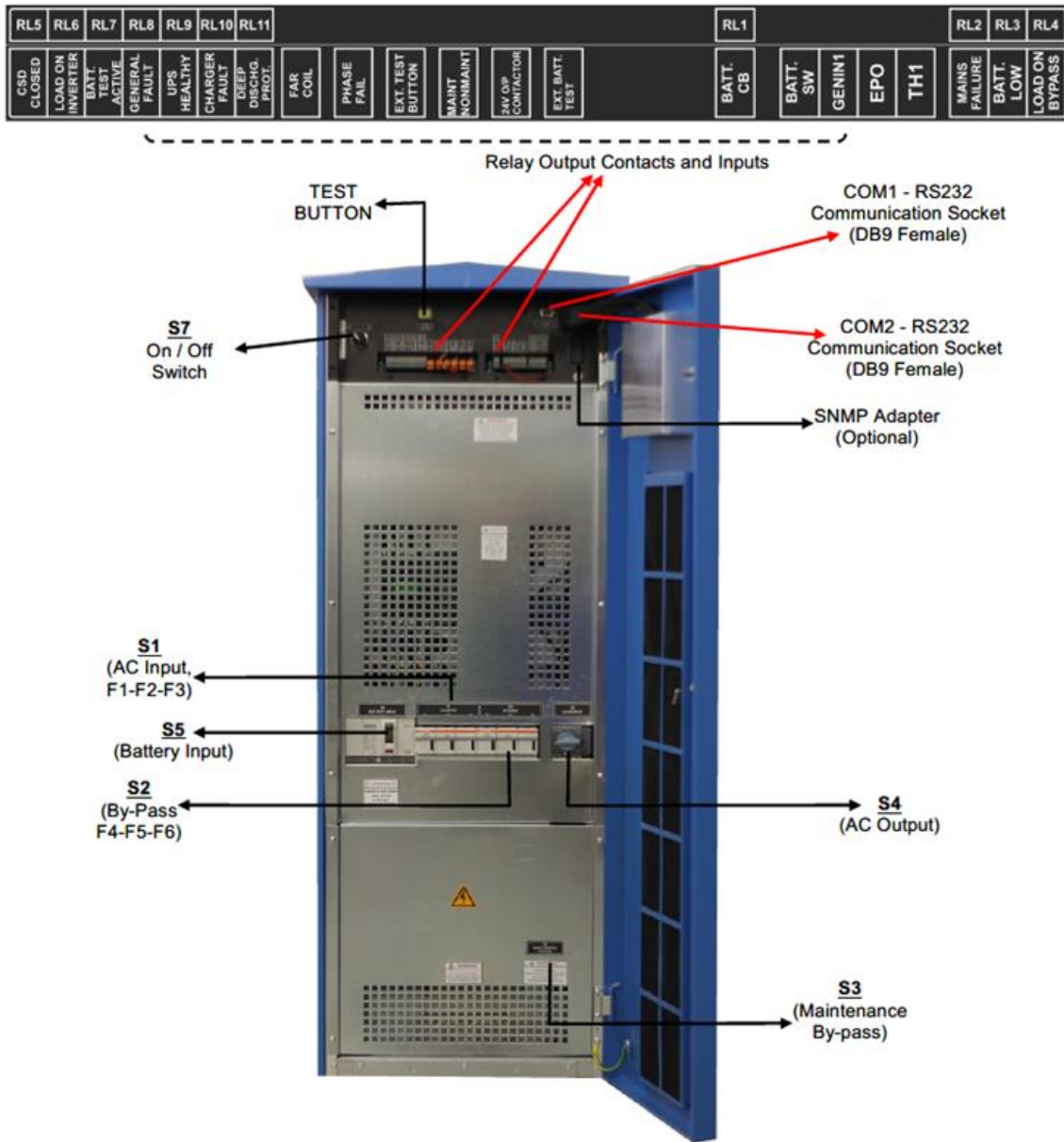

Figure 2.5B - 30-40 kVA Fuses and Switches Panel

RL5	RL6	RL7	RL8	RL9	RL10	RL11	RL1	RL2	RL3	RL4										
CSD CLOSED	LOAD ON INVERTER	BATT. SW ACTIVE	GENERAL FAULT	UPS HEALTHY	CHARGER FAULT	DEEP DISCHG. PROT.	FAR COIL	PHASE FAIL	EXT. TEST BUTTON	MAINT NONMAINT	FAV OVP CONTACTOR	EXT. BATT. TEST	BATT. CB	BATT. SW	GENINH	EPO	TH1	MAINS FAILURE	BATT. LOW	LOAD ON BYPASS

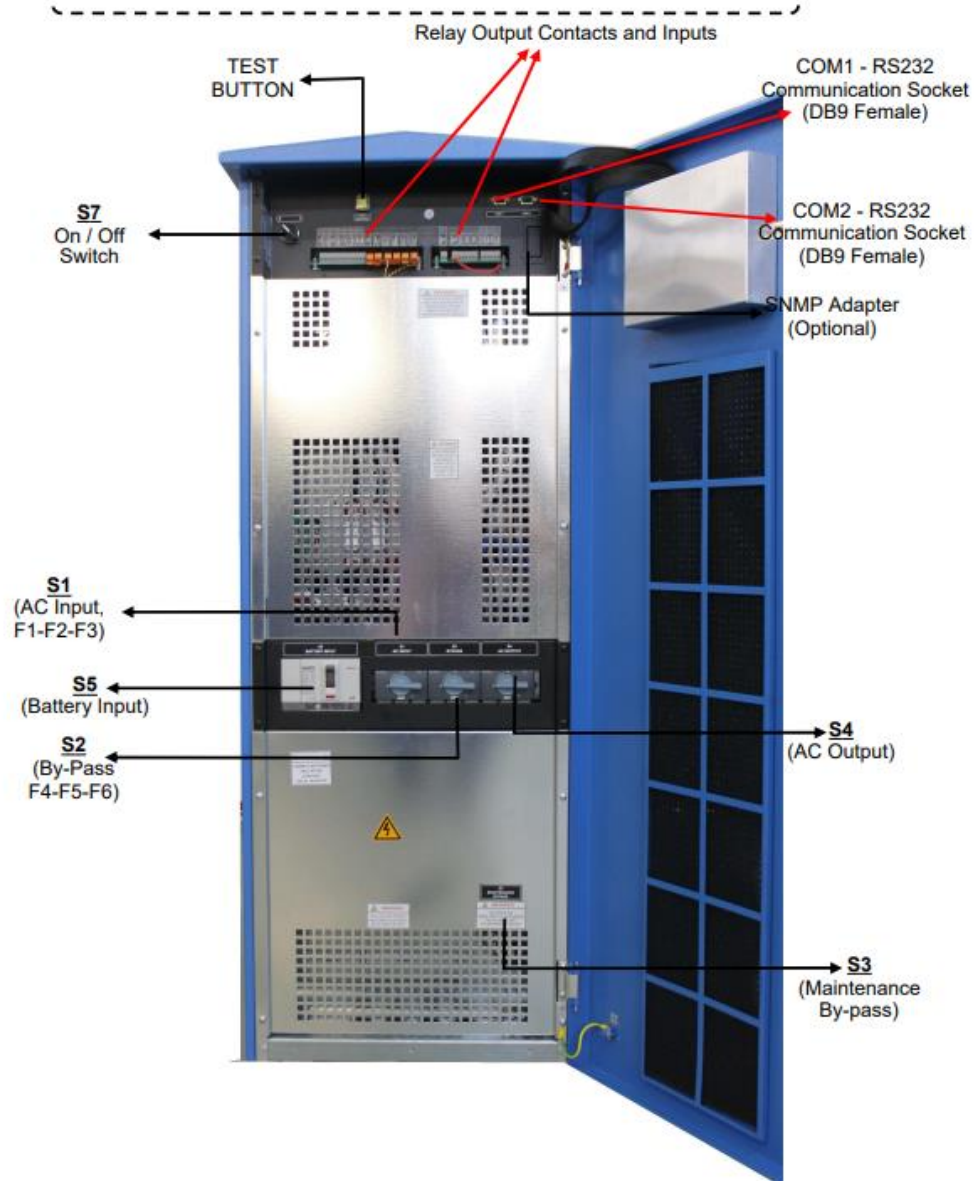
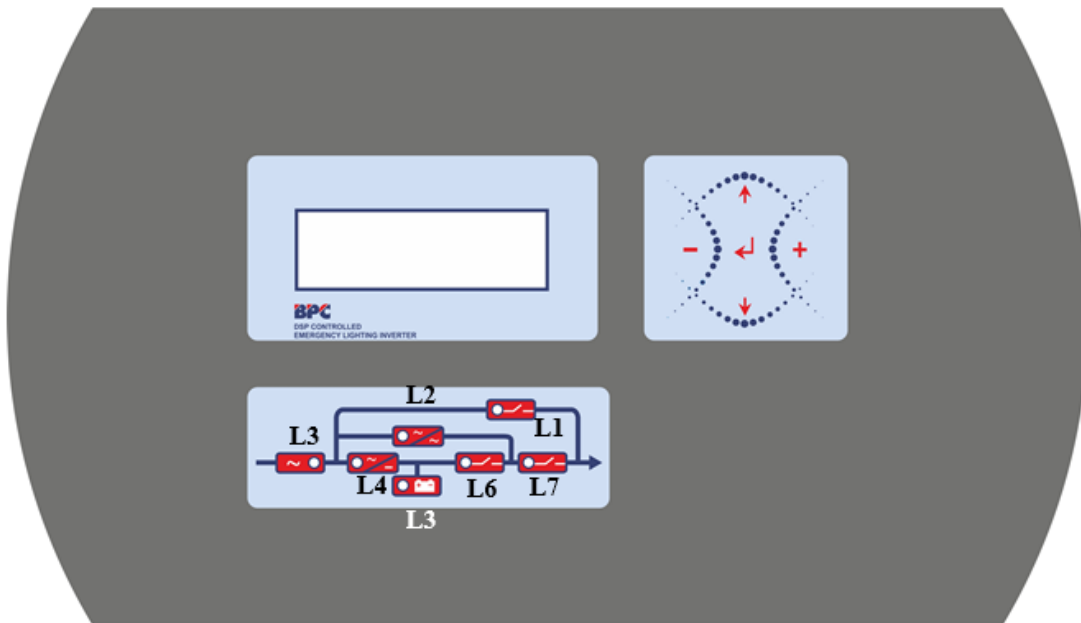

Figure 2.5C - 60 kVA Fuses and Switches Panel

2.3.2 CONTROL DISPLAY

The front panel of EL INVERTER, consisting of a 4 lines alphanumeric display, 7 status lamps, plus 5 function keys, allows the complete monitoring of the EL INVERTER status. The mimic flow diagram helps to comprehend the operating status of the EL INVERTER. By using the function keys operator can move on menus and change some parameters.



- L1 : Maintenance bypass switch on indicator lamp**
- L2 : Load on bypass indicator lamp**
- L3 : Input voltage indicator lamp**
- L4 : Rectifier run pilot lamp**
- L5 : Battery operation indicator lamp**
- L6 : Load on EL INVERTER indicator lamp**
- L7 : Output switch on indicator lamp**

There are 5 control buttons on the EL INVERTER Front panel, ENTER button provides selection declaration, up and down buttons provide to surf on menus, (+) and (-) buttons are used for adjustments or option selection.

2.3.4 DISPLAY SUB MENU

	Menu	Usage
1	STATUS	→ Enter Status menu
2	MEASUREMENTS	→ Enter Measurements menu
3	ALARM LOGS	→ Enter Alarm logs menu
4	INFORMATION	→ Enter Information menu
5	OPTIONS	→ Enter Options menu
6	COMMAND	→ Enter Command menu
7	TIME	→ Enter Time menu
8	SERVICE	→ Enter Service menu
9	PASSWORD	→ Enter Password screen
10	ADJUST	→ Enter Adjust menu
	Goto 1	

SUB MENU 2

Level 1	Level 2	Page	Level 3
STATUS	Status of the EL INVERTER		
MEASUREMENTS	INPUT		Input measurements
	BYPASS		Bypass measurements
	INVERTER		Inverter measurements
	OUTPUT		Output measurements
	DC		DC measurements
	GENERAL		General measurements
	ENTER - EXIT		
ALARM LOGS	EL INVERTER LOG RECORD	Page1	
	ENTER CLEAR LOG	Page1	
	ENTER - EXIT		
INFORMATION	RS232 Comm 1:-- 2:--	Page1	
	Maximum EL INVERTER power	Page1	
	Nominal voltage and frequency	Page1	
	Inverter firmware version	Page2	
	PFC firmware version	Page2	
	Panel firmware version	Page2	
	EL INVERTER Model	Page3	
	Communication protocol	Page3	
	Chassis nr	Page3	
ENTER - EXIT			
OPTIONS	LCD OPTIONS		LCD panel options
	COMM.OPTIONS		Communication options
	ALARM OPTIONS		Alarm options
	BYPASS OPTIONS		Bypass options
	ENTER - EXIT		
COMMAND	By-pass transfer	Page1	
	Boost charge start	Page1	
	Short battery test start	Page1	
	Relay check	Page2	
	Dialup modem programming	Page2	
	Alarm sound ON/OFF	Page3	
	Warning sound interval	Page3	
	ENTER - EXIT		
	TIME	Current time	Page1
Current date		Page1	
Set hour		Page2	
Set minute		Page2	
Set day		Page3	

Level 1	Level 2	Page	Level 3
	Set month	Page3	
	Set year	Page3	
	Update time and date	Page4	
	ENTER - EXIT		
SERVICE	Operating hourmeter	Page1	
	Maximum load	Page1	
	ENTER Fault reset	Page1	
	Fan maintenance hourmeter	Page2	
	Batt.maintenance hourmeter	Page2	
	General maintenance hourmeter	Page2	
	Logout command	Page3	
	ENTER - EXIT		
PASSWORD	Getting service code	Page1	
	Type service password	Page1	
	Type user password	Page1	
	ENTER - EXIT		
ADJUST (in English)			
	Group adjustments		Automatic settings
	Inverter factory options		Options list
	Rectifier factory options		Options list
	Panel adjustments		Options list
	AC input adjustments		AC input settings
	AC Bypass adjustments		AC bypass settings
	AC output adjustments		AC output settings
	DC adjustments		DC settings
	Power adjustments		Power settings
	ENTER - EXIT		

2.3.5 MEASUREMENTS MENU

All measured values of the EL INVERTER can be monitored from this menu.

Use up and down buttons to move on submenu.

MEASUREMENTS / INPUT (Level 2)

All rectifier input measurements are located in this menu, use up and down buttons to move on submenu.

MEASUREMENTS / INPUT Page 1 (Level 3)	
P-N L1 L2 L3	Page header
Vinp: 221/222/223 V	Phase to neutral measured AC input voltages
Iinp: 000/000/000 A	Measured RMS AC input phase currents
.....	Current alarm messages

Up previous page, down next page

MEASUREMENTS / INPUT Page 2 (Level 3)	
P-P L13 L21 L32	Page header
Vinp: 381/382/383 V	Phase to phase measured AC input voltages
Finp: 49.6 Hz	Measured rectifier input frequency
.....	Current alarm messages

Up previous page, down next page

MEASUREMENTS / INPUT Page 3 (Level 3)

ENTER - EXIT	ENTER exit to upper menu
.....	Current alarm messages

Up previous page, down next page

MEASUREMENTS / BYPASS (Level 2)

All by-pass input measurements are located in this menu, use up and down buttons to move on submenu.

MEASUREMENTS / BYPASS Page 1 (Level 3)

P-N L1 L2 L3	Page header
Vbyp: 221/222/223 V	Phase to neutral measured AC bypass input voltages
OK OK --	Bypass voltage status
.....	Current alarm messages

Up previous page, down next page

MEASUREMENTS / BYPASS Page 2 (Level 3)

P-P L13 L21 L32	Page header
Vbyp: 381/382/383 V	Phase to phase measured AC bypass input voltages
Fbyp: OK / 50.0 Hz	Measured bypass input frequency
.....	Current alarm messages

Up previous page, down next page

MEASUREMENTS / BYPASS Page 3 (Level 3)

ENTER - EXIT	ENTER exit to upper menu
.....	Current alarm messages

Up previous page, down next page

MEASUREMENTS / INVERTER MENU (Level 2)

All inverter measurements are located in this menu, use up and down buttons to move on submenu.

MEASUREMENTS / INVERTER Page 1 (Level 3)

P-N L1 L2 L3	Page header
Vinv: 221/222/223 V	Phase to neutral measured AC Inverter output voltages
Finv: 50.0 Hz	Measured Inverter output frequency
.....	Current alarm messages

Up previous page, down next page

MEASUREMENTS / INVERTER Page 2 (Level 3)

ENTER - EXIT	ENTER exit to upper menu
.....	Current alarm messages

Up previous page, down next page

MEASUREMENTS / OUTPUT MENU (Level 2)

All EL INVERTER output measurements are located in this menu, use up and down buttons to move on submenu.

MEASUREMENTS / OUTPUT Page 1 (Level 3)	
P-N L1 L2 L3	Page header
Vout: 221/222/223 V	Phase to neutral measured AC EL INVERTER output voltages
Iout: 00.0/00.0/00.0 A	Measured AC RMS load currents
.....	Current alarm messages

Up previous page, down next page

MEASUREMENTS / OUTPUT Page 2 (Level 3)	
P-P L13 L21 L32	Page header
Vout: 381/382/383 V	Phase to phase measured AC EL INVERTER output voltages
Fout: 50.0 Hz	Measured EL INVERTER output frequency
.....	Current alarm messages

Up previous page, down next page

MEASUREMENTS / OUTPUT Page 3 (Level 3)	
Load 000/000/000 %	Measured load percentage
KW 000.0/000.0/000.0	Measured output watt power
KVA 000.0/000.0/000.0	Measured output KVA power
.....	Current alarm messages

Up previous page, down next page

MEASUREMENTS / OUTPUT Page 4 (Level 3)	
PF: ---- ---- ----	Load power factor
C.F: 0.0 / 0.0 / 0.0	Load crest factor
.....	Current alarm messages

Up previous page, down next page

MEASUREMENTS / OUTPUT Page 5 (Level 3)	
ENTER - EXIT	ENTER exit to upper menu
.....	Current alarm messages

Up previous page, down next page

MEASUREMENTS / DC MENU (Level 2)

All DC measurements are located in this menu, use up and down buttons to move on submenu.

MEASUREMENTS / DC Page 1 (Level 3)	
Vbat 405/-405 V	Measured battery voltages
Ichg 00.0/00.0 A	Measured battery charge currents
Idisch 00.0/00.0 A	Measured battery discharge currents
.....	Current alarm messages

Up previous page, down next page

MEASUREMENTS / DC Page 2 (Level 3)	
Batteries : 30 x 2	Batteries in one group
Par.Batts : 1	Parallel battery groups
Batt. A/H : 007 Ah	Battery amper / hour rating
.....	Current alarm messages

Up previous page, down next page

MEASUREMENTS / DC Page 3 (Level 3)	
Backup time 0000 min	Calculated remaining time
.....	Current alarm messages

Up previous page, down next page

MEASUREMENTS / DC Page 4 (Level 3)	
ENTER - EXIT	ENTER exit to upper menu
.....	Current alarm messages

Up previous page, down next page

MEASUREMENTS / GENERAL MENU

Temperature measurements are located in this menu, use up and down buttons to move on submenu.

MEASUREMENTS / GENERAL Page 1 (Level 3)	
TH1: ---- C	Measured external sensor temperature
TH2: 24.2 C	Measured battery cabinet inside temperature
TH3: ---- C	Measured internal sensor temperature
.....	Current alarm messages

Up previous page, down next page

MEASUREMENTS / GENERAL Page 2 (Level 3)	
ENTER - EXIT	ENTER exit to upper menu
.....	Current alarm messages

Up previous page, down next page

2.3.6 ALARMS LOG MENU

Use this menu to see the alarm log records.

ALARM LOGS Page 1 (Level 2)	
EL INVERTER LOG RECORD	Page header
>001>081110 14:33:26	Event no, date and time (left and right buttons move)
ENTER CLEAR LOG	ENTER button clears all log memory
.....	Current alarm messages

Up upper line, down next line

ALARM LOGS Page 2 (Level 2)	
ENTER - EXIT	ENTER exit to upper menu
.....	Current alarm messages

Up previous page, down next page

2.3.7 INFORMATION MENU

Some useful information is in this menu , use the up and down buttons to move on submenu.

INFORMATION MENU Page 1 (Level 2)	
RS232 Comm: 1:- 2--	RS232 activity indicator for com1 and com2
MAX Power: 60000 VA	Maximum EL INVERTER output power as VA
Nom:220/050 220/050	Nominal input, output voltage and frequency
.....	Current alarm messages

Up previous page, down next page

INFORMATION MENU Page 2 (Level 2)	
Inv version: 00001	Inverter module firmware version
Pfc version:00001	PFC rectifier module firmware version
Lcd version:00001	Front panel module firmware version
.....	Current alarm messages

Up previous page, down next page

INFORMATION MENU Page 3 (Level 2)	
Model:CL360D	Model name of the EL INVERTER
Protocol:TX301	Communication protocol version
Chassis nr: 123456	EL INVERTER chassis nr
.....	Current alarm messages

Up previous page, down next page

INFORMATION MENU Page 4 (Level 2)	
ENTER - EXIT	ENTER exit to upper menu
.....	Current alarm messages

Up previous page, down next page

2.3.8 OPTIONS MENU

Use up and down buttons to move cursor on submenu at the end of page you move to next page. Menu has 3 level structure, if user password is enabled some parameters requires user password.

Level 3 LCD panel options group			
	Panel language selection	Page1	
	Button click ON/OFF	Page1	
	LCD backlight brightness	Page2	
	Backlight delay	Page2	
	Backlight dim.delay	Page2	
	ENTER - EXIT	Page3	

OPTIONS / LCD OPTIONS Page 1 (Level 3)	
>LANGUAGE:ENGLISH	Left and right change panel language (P3330)
CLICK: ON/OFF	Left and right button click sound ON/OFF
.....	Current alarm messages

Up upper line, down next line, (+) or (-) options, ENTER select an option.

OPTIONS / LCD OPTIONS Page 2 (Level 3)	
>BACKLIGHT:XXXXXXXX	Left and right LCD backlight brightness adjust
BL DELAY:CLOSED	Backlight delay
BL DIM:CLOSED	Back light half option selection
.....	Current alarm messages

Up upper line, down next line, (+) or (-) options, ENTER select an option.

OPTIONS / LCD OPTIONS Page 3 (Level 3)	
ENTER - EXIT	ENTER exit to upper menu
.....	Current alarm messages

Up previous page, down next page

Level 3 – Communication options			
	Remote control ON/OFF	Page1	
	COM2 port function	Page1	
	SNMP internal/external	Page1	
	Relay 1 function selection	Page2	
	Relay 2 function selection	Page2	
	Relay 3 function selection	Page2	
	Relay 4 function selection	Page3	
	Relay 5 function selection	Page3	Optional
	Relay 6 function selection	Page3	Optional
	Relay 7 function selection	Page4	Optional
	Relay 8 function selection	Page4	Optional
	Relay 9 function selection	Page4	Optional
	Relay 10 function selection	Page5	Optional
	Relay 11 function selection	Page5	Optional

	Relay 12 function selection	Page5	Optional
	REPO input ON/OFF	Page6	
	ENTER - EXIT	Page7	

OPTIONS / COMMUNICATION OPTIONS Page 1 (Level 3)

REMOTE CNTRL: ON/OFF	Left and right remote control ON/OFF
>COM2:SERVICE PORT	Com 2 serial port function selection
SNMP : INTERNAL/EXTERNAL	SNMP adaptor location
.....	Current alarm messages

Up upper line, down next line, (+) or (-) options, ENTER select an option.

OPTIONS / COMMUNICATION OPTIONS Page 2 (Level 3)

>RELAY1:	Left and right button relay function selection
RELAY 2:	Left and right button relay function selection
RELAY 3:	Left and right button relay function selection
.....	Current alarm messages

Up upper line, down next line, (+) or (-) options, ENTER select an option.

OPTIONS / COMMUNICATION OPTIONS Page 3 (Level 3)

> RELAY 4:	Left and right button relay function selection
RELAY 5:	<i>CANNOT BE SELECTED</i>
RELAY 6:	<i>CANNOT BE SELECTED</i>
.....	Current alarm messages

Up upper line, down next line, (+) or (-) options, ENTER select an option.

OPTIONS / COMMUNICATION OPTIONS Page 4 (Level 3)

> RELAY 7:	<i>CANNOT BE SELECTED</i>
RELAY 8:	Left and right button relay function selection (option)
RELAY 9:	<i>CANNOT BE SELECTED</i>
.....	Current alarm messages

Up upper line, down next line, (+) or (-) options, ENTER select an option.

OPTIONS / COMMUNICATION OPTIONS Page 5 (Level 3)

> RELAY 10:	Left and right button relay function selection (option)
RELAY 11:	<i>CANNOT BE SELECTED</i>
RELAY 12:	<i>CANNOT BE SELECTED</i>
.....	Current alarm messages

Up upper line, down next line, (+) or (-) options, ENTER select an option.

OPTIONS / COMMUNICATION OPTIONS Page 6 (Level 3)

REPO : ON / OFF	Emergency stop input enabled or disabled
.....	Current alarm messages

Up upper line, down next line, (+) or (-) options, ENTER select an option.

OPTIONS / COMMUNICATION OPTIONS Page 7 (Level 3)

ENTER - EXIT	ENTER exit to upper menu
.....	Current alarm messages

Up previous page, down next page

Level 3 Alarm options			
	Warning beep interval	Page1	
	Warning log ON/OFF	Page1	
	Status log ON/OFF	Page1	
	ALF restart ON/OFF	Page2	
	ENTER - EXIT	Page3	

OPTIONS / ALARM OPTIONS Page 1 (Level 3)	
>WARNING INTRVL:10 sc	Warning beep interval adjustment in seconds
WARNING LOG:ON/OFF	Left and right warning LOG record ON/OFF
STATUS LOG:ON/OFF	Left and right status log record ON/OFF
.....	Current alarm messages

Up upper line, down next line, (+) or (-) options, ENTER select an option.

OPTIONS / ALARM OPTIONS Page 2 (Level 3)	
>ALF RESTART: USER/AUTO	During mains restore start USER/AUTO (R1174/2)
.....	Current alarm messages

Up upper line, down next line, (+) or (-) options, ENTER select an option.

OPTIONS / ALARM OPTIONS Page 3 (Level 3)	
ENTER - EXIT	ENTER exit to upper menu
.....	Current alarm messages

Up previous page, down next page

Level 3 - Bypass options			
	VAT transfer ON/OFF	Page1	
	Gen set bypass ON/OFF	Page1	
	Gen set synchron ON/OFF	Page1	
	ENTER - EXIT	Page2	

OPTIONS / BYPASS OPTIONS Page 1 (Level 3)	
VAT TRANSFER:ON/OFF	Left and right VAT transfer system ON/OFF (R1174/3)
>GEN SET BYP:FORBID/FREE	Left and right bypass to generator FORBID/FREE (R1174/5)
GEN SET SYNC:XTAL/SYNC	Left and right generator synchron XTAL/SYNC (R1174/6)
.....	Current alarm messages

Up upper line, down next line, (+) or (-) options, ENTER select an option.

OPTIONS / BYPASS OPTIONS Page 2 (Level 3)	
ENTER - EXIT	ENTER exit to upper menu
.....	Current alarm messages

Up previous page, down next page

OPTIONS / LIGHTING INVERTER OPTIONS Page 1

MODE : CHANGEOVER	
BATT. TEST SW : NO	

OPTIONS / LIGHTING INVERTER OPTIONS Page 2

TEST1	
TEST2	

OPTIONS / LIGHTING INVERTER OPTIONS Page 3

ENTER - EXIT	
--------------	--

2.3.8 COMMAND MENU

This menu contains EL INVERTER commands be careful while using commands.

Use up and down buttons to move cursor on submenu at the end of page you move to next page.
<ENTER> button applies the related command.

COMMAND MENU Page 1 (Level 2)

> ENTER <BYPASS>	ENTER transfer the load to bypass
ENTER <BOOST>	ENTER start boost charge mode
ENTER B.TEST > 405	ENTER start short battery test
.....	Current alarm messages

Up upper line, down next line, (+) or (-) options, ENTER apply command.

COMMAND MENU Page 2 (Level 2)

> RELAY TEST:OFF	Left and right test dry contact relays
ENTER : MODEM INIT	ENTER initialize dialup modem
.....	Current alarm messages

Up upper line, down next line, (+) or (-) options, ENTER apply command.

COMMAND MENU Page 3 (Level 2)

> ALARM SOUND: ON/OFF	Left and right disable alarm buzzer
MIMIC LED TEST	ENTER lamp test
.....	Current alarm messages

Up upper line, down next line, (+) or (-) options, ENTER apply command.

COMMAND MENU Page 4 (Level 2)

ENTER - EXIT	ENTER exit to upper menu
.....	Current alarm messages

Up previous page, down next page

2.3.8 TIME MENU

You can see Time and date information of the RTC clock in the EL INVERTER ,also you can set date and time from this menu.

TIME MENU Page 1 (Level 2)	
>TIME : 15:47:20	Time of EL INVERTER RTC
DATE: 31/12/2010	Date of EL INVERTER RTC
.....	Current alarm messages

Up previous page, down next page

TIME MENU Page 2 (Level 2)	
>SET HOURS : 15	Left and right set hours
SET MINS : 47	Left and right set minutes
.....	Current alarm messages

Up upper line, down next line, (+) or (-) adjust.

TIME MENU Page 3 (Level 2)	
>SET DAY : 31	Left and right set day of month
SET MONTH : 12	Left and right set month
SET YEAR : 11	Left and right set year
.....	Current alarm messages

Up upper line, down next line, (+) or (-) adjust.

TIME MENU Page 4 (Level 2)	
ENTER <UPDATE>	ENTER apply new time and date settings
.....	Current alarm messages

Up previous page, down next page, ENTER apply new time and date settings.

TIME MENU Page 5 (Level 2)	
ENTER - EXIT	ENTER exit to upper menu
.....	Current alarm messages

Up previous page, down next page

2.3.8 SERVICE MENU

This menu contains some helpful service information and some commands. Use up and down buttons to move cursor on submenu at the end of page you move to next page.

SERVICE MENU Page 1 (Level 2)	
>HOURMETER:00075	Total operating hour of the EL INVERTER
MAXLOAD:015 020 025 %	From power on recorded maximum power
ENTER<FAULT RESET>	ENTER fault reset
.....	Current alarm messages

Up upper line, down next line

SERVICE MENU Page 2 (Level 2)	
FAN MAINT: 01000	Remaining hours to FAN maintenance
BAT MAINT :01200	Remaining hours to battery maintenance
GEN.MAINT: 00500	Remaining hours to general maintenance
.....	Current alarm messages

If maintenance counters are disabled CANCEL word is shown.

SERVICE MENU Page 3 (Level 2)	
>LOGOUT: --	ENTER Exit from service login status
.....	Current alarm messages

Up previous page, down next page, ENTER Logout from login status.

SERVICE MENU Page 4 (Level 2)	
ENTER - EXIT	ENTER to EXIT from menu and return to upper level
.....	current alarms appear sequentially

2.3.8 ADJUST MENU

This menu is prepared for service purposes there is no user adjustable parameter in this menu.

2.3.8 USER PASSWORD

Some commands or some option selections are required user password, if menu position is required password window comes to screen and EL INVERTER asks for user password. If you lost user password our service personnel will recover your user password.

User password is 4 digits numbers, move cursor with left and right buttons, select digit and adjust the number with up and down buttons. Do this for all digits and if password is typed completely press ENTER button. If the password is correct A43 USER LOGIN message will be shown on the LCD panel of the EL INVERTER.

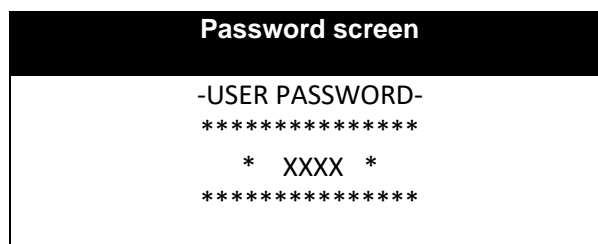

Only authorized service personnel has the useful password. Therefore, it is hidden at above display.

CHAPTER 3 – INSTALLATION

3.1 INTRODUCTION



WARNING: All the operations described in this chapter must be supervised by suitably qualified personnel and all aspects of the electrical installation must be carried out by an authorised electrician.

BPC Energy Ltd. will take no responsibility for any personal injury or material damage caused by incorrect cabling or operation, or any installation activities that are not carried out in strict accordance with the instructions contained in this manual.



WARNING: Once the PowerPro EL 300DSP system is installed it must be commissioned by an engineer approved by BPC Energy Ltd, or one of its service agents, before it is powered-up.

BPC Energy Ltd. will take no responsibility for any personal injury or material damage caused by the application of electrical power to this equipment before it has been fully commissioned.

3.2 ACCEPTING DELIVERY

The PowerPro EL 300DSP cabinet is shipped on a purpose-built pallet that is easy to move with a forklift or a pallet truck. The power modules, batteries and other accessories are shipped separately.



CAUTION: Observe the following precautions when off-loading and moving the cabinet:

- Always keep the packages in an upright position.
- Do not drop the equipment.
- Do not stack the pallets.

The cabinet is bolted to the shipping pallet and packed in a cardboard sleeve that is designed to protect it from mechanical and environmental damage. Further protection is provided by wrapping the equipment with a plastic sheet.

Before you accept the shipment ensure that the received package(s) correspond to the description shown in the delivery documentation and carefully examine the packing containers for signs of physical damage

3.2.1 REPORTING DAMAGE

Claims for shipping damage must be filed immediately when found, and the carrier must be informed of ALL claims within seven days of receipt of the equipment. If the equipment is to be stored for longer than seven days before it is installed, you should unpack it and inspect it for signs of internal damage before you put it into storage. Note that some optional equipment packages might be shipped inside the cabinet, and these too should be checked for damage.

If the equipment is damaged, you should store the packing materials for further investigation.

3.2.2 STORAGE

If you plan to store the PowerPro EL 300DSP prior to its installation it should be kept upright (preferably in its original shipping packaging) in a clean, dry environment with a temperature between -25°C to +60°C and RH <93%.

If the storage period is likely to exceed seven days, the packaging should be removed, and the cabinet inspected for shipping damage before it is placed into storage. If there is no apparent damage, you should refit the packaging or cover the cabinet with a dustcover to prevent the ingress of dust and dirt.

Batteries that are intended for external rack-mounting will be shipped in a separate package and should be stored under the environmental conditions stipulated above.

3.2.3 UNPACKING INSTRUCTIONS



WARNING: The cabinet, battery cabinet (optional) and battery packages are heavy and may tip during unpacking unless the unpacking instructions are not followed closely.

If the shipment is received in good order, please unpack the PowerPro EL 300DSP cabinet as follows:

1. Remove the plastic sheeting and cardboard sleeve covering the cabinet.
2. Remove the anchor bolts securing the cabinet to the pallet then lift and remove the cabinet from the pallet.
3. Retain the packaging materials for possible future shipment.
4. Examine the cabinet for any sign of damage and notify your supplier immediately if any damage is found.
5. Remove any internal protective packaging.
6. When the cabinet is placed in its final location, install the 4kVA power modules and secure them in place.
7. Install a blanking plate to the front of any shelves that have no power module fitted.

Batteries



CAUTION: The system batteries must ALWAYS be installed by the commissioning engineer.



WARNING: If the system is delivered without batteries, BPC Energy Ltd. will not accept responsibility for any damage or equipment malfunctioning caused by the incorrect storage, installation or connection of batteries carried out by third parties.

The batteries are shipped in a separate package and should remain in their packing until required by the BPC Energy Ltd. service engineer when the system is commissioned. Battery life depends very much on the ambient temperature, and optimum battery life will be obtained if the batteries are stored and operated at a temperature of 20°C.

3.3 INSTALLATION

3.3.1 ENVIRONMENTAL CONSIDERATIONS

A certain amount of pre-planning will help provide a trouble-free installation process. You should consider the following guidelines when planning the installation location and operating environment.

1. The route to the installation location must allow the equipment to be transported in an upright position.
2. The floor at the proposed installation site and en-route from the off-loading point must be able to safely support the weight of the cabinet/battery equipment, plus forklift or trolley jack during transit.
3. The cabinet requires sufficient front and rear clearance to enable cooling airflow, as described below.
4. All maintenance, servicing and user operation can be carried out from the front of the cabinet, but rear access is required for connecting the AC and DC power cables.
5. An ambient temperature of 20°C is necessary to achieve the recommended battery life span.
6. The cooling air entering the cabinet must not exceed +40°C.
7. The floor material should be non-flammable and strong enough to support the heavy load.

In summary, the system should be installed in a location where:

- a) Humidity (< 93%) and temperature is ideally 20°C.
- b) Fire protection standards are respected.
- c) Cabling can be performed easily.
- d) A minimum 600mm front accessibility is available for service or periodic maintenance.
- e) Adequate cooling air flow is available.
- f) The air conditioning system can provide a sufficient amount of air cooling to keep the room at, or below, the maximum desired temperature (where used).
- g) No dust or corrosive/explosive gases are present.
- h) The location is vibration free.

3.3.2 CLEARANCES

Cooling air enters the front of the power modules and force ventilate through the cabinet rear.

- A. You should provide a minimum of 600mm clearance at the front of the cabinet to allow the power module(s) to be removed/installed.
- B. You should provide a minimum of 300mm at the rear of the cabinet and 700mm above the cabinet.
- C. You should provide a minimum of 600mm clearance to the sides of the cabinet for cooling purposes and maintenance.

The battery installation is bespoke, and specific access clearances will be specified by the battery installation designer.

3.3.4 CABLE CONSIDERATIONS

It is the customer's responsibility to design and install the PowerPro EL 300DSP supply and distribution circuits, and provide all the external fuses, switchgear and cables required to connect the cabinet's AC INPUT, DC INPUT and SI OUTPUT supplies. The information provided in this section should assist you in the planning and preparation of the power cabling.

The AC INPUT terminals should be connected to a utility mains LV-switchgear panel and protected by a circuit breaker or fused isolator. The protective device not only offers overload protection but also provides a means of disconnecting the mains supply from the PowerPro EL 300DSP, as there is no input supply switch fitted to the standard cabinet.

A fused battery isolator must be fitted inside the external battery cabinet – or immediately adjacent to the battery installation if a purpose-designed battery cabinet is not used. This requires a three-pole device, connected to the battery positive, negative, and mid-point (neutral), as shown. BPC Energy Ltd. can supply a matching battery cabinet containing the necessary fuses and switchgear.

Similarly, the SI OUTPUT terminals should be connected to the load equipment via a suitably protected load distribution panel.

The recommended output circuit breakers are specified in the following table.

OUTPUT DEVICE TYPE						
SYSTEM SIZE	B4	B6	B10	B16	C10	C16
EL310DSP	YES	NO	NO	NO	NO	NO
EL320DSP	YES	YES	NO	NO	NO	NO
EL330DSP	YES	YES	NO	NO	NO	NO
EL340DSP	YES	YES	YES	YES	YES	NO
EL360DSP	YES	YES	YES	YES	YES	YES

Table 3.1

Table indicates units manufactured from 01.01.2023

3.3.5 INRUSH CURRENT

Special Consideration should be taken when installing luminaires with very high inrush characteristics.

The Inrush Current of LED Luminaires is determined by the driver (s) and is not proportional to the luminaire wattage or running current, LED luminaire inrush currents can be as high as 400 times the running current for a very short period of time.

Further information regarding LED inrush currents can be found by accessing the “LIA Technical Statement LIA TS35” from the LIA website (www.thelia.org.uk).

The table below provides some details regarding the maximum recommended inrush currents for luminaires:

SYSTEM SIZE	Maximum Inrush Current
EL310DSP	39A
EL320DSP	78A
EL330DSP	117A
EL340DSP	157A
EL360DSP	274A

If higher inrush levels are expected BPC Energy Ltd can provide Inrush Current Limiter for LED lighting Drivers.

Rated at maximum 16A continuous power they can be installed within lighting distribution panels.

3.3.6 CABLE SPECIFICATION

All cables and protective devices must be selected in accordance with national and local regulations and codes of practice (e.g., BS7671:2008 or relevant country standards) to suit the maximum capacity of the system, as shown in the table below.

NOTE: If you install a system containing fewer than six power modules with a view to increasing the system capacity it at a later date as your load increases, you should consider using cables rated for the maximum system rating at the outset. This will simplify the future update process and avoid having to shut down the system at a later date to replace the power cables. ALL power modules have internal fuse protection.

EL INVERTER power. (kVA)	Current	Recommended cable size (mm ²)			Terminal Size	
	Max Input current (A) per phase @120% resistive load, Full charge current. (230V)	Line input	Bypass input / EL INVERTER output	External Battery	Input / output Cable connections L1-L2-L3-N	Battery connections + & -
EL310DSP	22A	10	10	10	16mm ² terminal	16mm ² terminal
EL320DSP	47A	16	16	16	16mm ² terminal	16mm ² terminal
EL330DSP	66A	16	16	16	35mm ² terminal	35mm ² terminal
EL340DSP	89A	25	25	25	35mm ² terminal	35mm ² terminal
EL360DSP	131A	35	35	35	35mm ² terminal	35mm ² terminal

Table 3.2

NOTE: The neutral conductor should be sized for 1,5 times the output/bypass phase current. These recommendations are for guideline purposes only and are superseded by local regulations and codes of practice.

NOTE: If using SWA cable on solid floor it is advised to install a plinth to allow better bend radius and glanding..

3.3.7 ELECTRICAL PLANNING

All electrical power connections are made to terminals located on the rear of the cabinet near the top. Gland plates are fitted to the top and bottom of the cabinet immediately above the power terminals to allow either top or bottom cable entry.

If the cabinet is to be installed in a location with restricted rear access, you should ensure that suitably contained power cables are available before the cabinet is moved to its intended final position.

3.3.8 CABLING PROCEDURE

3.3.8.1 SAFETY NOTES

Please ensure you read and understand the following safety notes before you begin the electrical installation.

1. All the operations detailed in this section must be performed or supervised by a qualified, authorised electrician.
2. Once the electrical installation is completed the initial system start-up must be performed by a qualified engineer, trained and authorised by BPC Energy.
3. Do not connect the system if there is water or moisture present.

4. When working on the input power cables, you must ensure that the AC INPUT supply is isolated at the mains switchgear panel and, where possible, locked out. Warning notices should be posted where applicable to prevent the inadvertent operation of the LV supply isolator(s).
5. Ensure the following conditions are met prior to starting work on the equipment:
 - a) No mains voltage is present from the mains switchgear panel.
 - b) All loads are shut down and disconnected.

3.3.8.2 TERMINAL CONNECTIONS

All Terminal connections can be found at the rear of the cabinet as per figure 3.3.

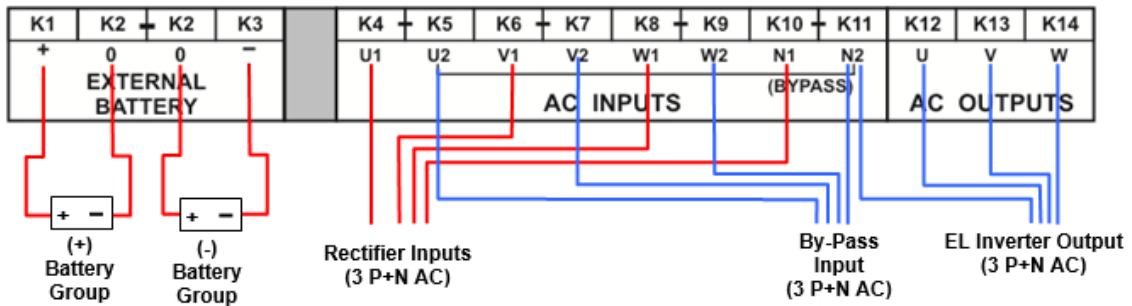

Figure 3.3a 10-20KVA CABLE CONNECTIONS

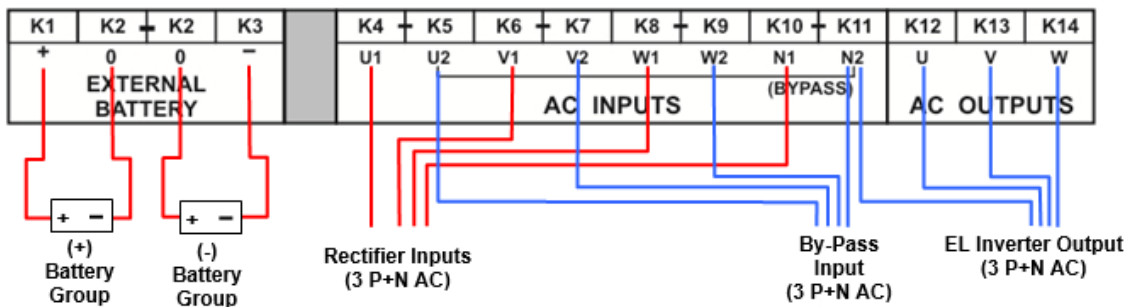

Figure 3.3b 30KVA CABLE CONNECTIONS

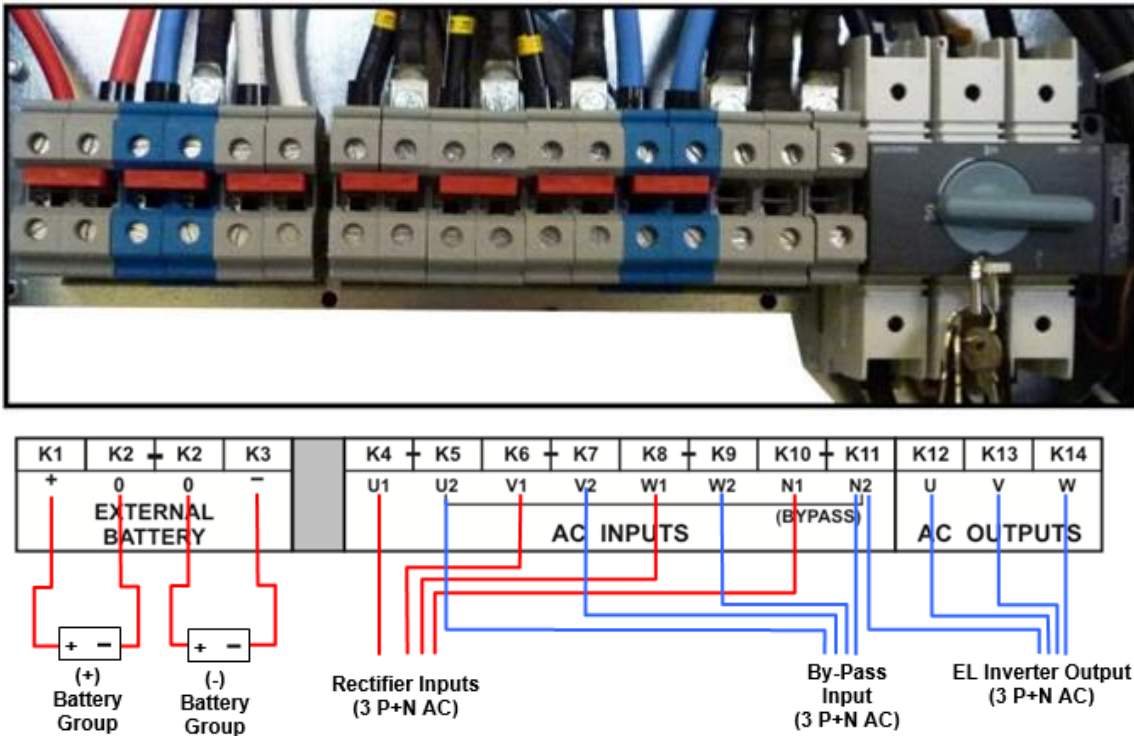

Figure 3.3c 40-60KVA CABLE CONNECTIONS

- As shown on the power connection label of the EL INVERTER, U1, V1 and W1 phase of the incoming 3 phase supply are used as the bypass inputs under normal conditions, if there is not a separate bypass supply (split bypass).

- If there is a separate 3- phase AC supply for bypass (Split Bypass):

a-) Remove the links between K4 – K5, K6 – K7 and K8 – K9.

b-) Connect the phases of the bypass source U2, V2 and W2 to K5, K7 and K9 respectively.

c-) Connect the Neutral (N2) of the Bypass source to K11.

Note that the Neutral of the 3-phase input supply (N1) and the Neutral of the 3-phase bypass supply (N2) must always be connected together to form the Neutral of the AC output.

Battery Cables

The DC cabling for the battery system(s) must be completed by an BPC Energy Ltd. engineer or one of its approved service agents. The customer installation team is only responsible for providing any necessary containment for the DC cables.



WARNING: Do not attempt to fit the batteries, complete the battery wiring, or close the battery isolator

CHAPTER 4 – OPERATION INSTRUCTIONS

4.1 START UP

Note: When you turn on the PowerPro EL 300DSP system its initial operating mode depends on the working conditions that were present when the system was previously shut down. This procedure covers the complete sequence of actions required to turn on the system from a fully powered-down state and then select the wanted operating mode.



WARNING: EL INVERTER should never be operated without neutral connection.



WARNING: EL INVERTER should never be started with its Battery Connected, and only started when the rectifier is operational. Incorrect procedure can result in Fuse or internal failure.

1. Turn on the input mains supply:
2. Ensure that all the switches and fuses (S1,S2,S3,S4 and S5) are in “off” position.
3. Turn ON S1 (AC Input) switch (switch to “1” position)
4. Turn ON S2 (static bypass) switch (switch to “1” position)
5. Turn ON S4 (AC Output) switch (switch to “1” position)
6. Turn ON S7 (On/Off) switch (to “1” position). LCD panel activates, and “INV RESET” or “PFC RESET” message appears on the display meaning that the rectifier starts to operate.
7. A few seconds later red bypass light (L2) on front panel turns off and green inverter light (L6) turns on. L6 light indicates that the EL Inverter has started normal operation and generating uninterruptable power for the critical load.
8. Turn on S5 switch to “1” position (and/or the external battery circuit breaker, if installed) to connect the battery group to EL Inverter.
9. EL Inverter is ready and operating in changeover mode now.

4.2 SHUT DOWN

This Procedure will completely shut down the Inverter and disconnect the load.

1. Turn OFF S5 switch to “0” position (and/or the external battery circuit breaker, if installed) to disconnect the battery group from the EL Inverter.
2. Turn OFF S7 (On/Off) switch (to “0” position). LCD panel deactivates.
3. Turn OFF S4 (AC Output) switch (switch to “0” position)
4. Turn OFF S2 (static bypass) switch (switch to “0” position)
5. Turn OFF S1 (AC Input) switch (switch to “0” position)

4.3 CHANGE OVER MODE TO INVERTER MODE

- Using the UP-DOWN buttons on the front panel, select “OPTIONS MENU” on LCD and press “ENTER” When you see “MODE : CHANGE OVER” or “MODE : INVERTER” on first page, select either “CHANGE OVER” or “INVERTER” mode using (+) and (-) buttons.
- After selecting the desired operation mode, press “ENTER” to send the command.

Turn off the EL Inverter and after a few seconds turn it on again by using the S7 On/Off Switch. Now the unit will start operating in the selected mode.

CHAPTER 5 – MAINTENANCE INSTRUCTIONS

The PowerPro EL 300DSP does not contain any user-serviceable parts, so day-to-day maintenance requirements are minimal other than to ensure that the operating environment is kept cool and dust free. A clean operating environment will help maximise the useful working life and reliability of both the PowerPro EL 300DSP and its batteries.

5.1 EMERGENCY LIGHTING MAINTENANCE

The PowerPro EL 300DSP system should be maintained as per the regulations set out in EN50172 Standards:

- Logbook Should be kept on site indicating all testing / inspection reports as detailed within the standard.
- Daily – Indicators of central power supply should be visually inspected for operation.
- Monthly – All luminaires and exit signs should be put into test and transferred to the central battery supply. The Central Battery system should be put into test and all luminaires checked for operation.
After return to normal operation the central battery system should be checked for normal operation.
- Annually – The specific Monthly test should be conducted for the full duration of the system. After restart the charging of the batteries should be fully checked for operation. Certificate / Test sheet should be recorded within the logbook.

5.2 SCHEDULED MAINTENANCE

The PowerPro EL 300DSP does not contain any user-serviceable parts, however the UPS contains life limited components (Capacitors and Fans) that require to be replaced at regular intervals, so day-to-day maintenance requirements are minimal other than to ensure that the operating environment is kept cool and dust free, we recommend that the UPS and batteries are inspected and calibrated on a 12 monthly basis (6 months depending on environment) as part of a preventative maintenance schedule to maximise the system's performance, working life and reliability. A clean operating environment will help maximise the useful working life and reliability of both the PowerPro EL300 DSP and its batteries.

EL300DSP Series EL INVERTER informs the user about specific maintenance when the maintenance time has elapsed with its 3 independent hour counter as warnings:

FAN MAINTENANCE counter
BATTERY MAINTENANCE counter
GENERAL MAINTENANCE counter

5.2.1 Preventative maintenance inspection

Preventative maintenance inspections form an integral part of all Extended Warranty Agreements (maintenance contracts) offered by BPC Energy Ltd.

During a preventative maintenance inspection, the engineer will check and validate:

- Site environmental conditions
- Integrity of electrical installation
- Cooling airflow
- Load characteristics
- Integrity of alarm and monitoring systems
- Operation of all installed options.

5.2.2 Battery maintenance and testing

The battery installation should be inspected on a regular basis, not exceeding 12-months. Traditional VLRA battery testing and maintenance consists of:

- Checking and recording the open-circuit battery voltage
- Verifying that the float charging voltage is correct
- Inspecting all battery terminals and connections for corrosion
- Inspecting all batteries for cracks, leaks or swelling
- Checking the integrity of the inter-cell connections
- Removing any materials and cleaning around the equipment
- Carry out a full battery check.

CHAPTER 6 – TROUBLE SHOOTING

The PowerPro EL 300DSP will generate an audible warning if a fault or abnormal operating condition is detected and indicate the source of the alarm trigger on the LCD panel.

There are no user-serviceable parts in the PowerPro EL 300DSP cabinet, so the degree of rectification that can be carried out by the operator is minimal, apart from ensuring that the system's AC and DC power supplies are available and within specification, and the load connected to the UPS OUTPUT is within the cabinet rating.

An internal fault can usually be attributed to a faulty power module, control panel or an ancillary assembly such as the cooling fan, all of which require the attention of a trained engineer who will exchange the faulty assembly in most instances.

6.1 ALARMS AND WARNING MESSAGES

The internal structure of the EL300DSP Series EL INVERTER is modular, these are:

- PFC Rectifier module
- Inverter module
- Front panel module

Module alarms and warnings are categorized according to modules at the front of the Alarm or warning message module information is added:

- RXX Rectifier alarms and warnings
- AXX Inverter alarms and warnings
- LXX LCD front panel alarms and warnings

More than one alarm can be shown on the EL INVERTER front panel with time shared order. If 4 alarms occur at the same time every 2 seconds 1 message will be showed, next 2 seconds 2.message will be showed etc.

If A00 or R00 Alarm is shown on the LCD panel, we understand that there is a system fault at the related module. We saw the message in the A00 INV FAULT = XXXX or R00 PFC FAULT = XXXX format. Numbers shown in X determine the status code which tells the problem to us. See status code table for details of codes.

Rectifier module alarm codes		
REC CODE = XXXX		XXXX SYSTEM fault occurred at the rectifier module
R00 REC FAULT = XXXX	Fault	Rectifier AC input voltage is high. CALL SERVICE !
R01 AC INPUT HIGH	Alarm	Rectifier AC input voltage is low
R02 LINE FAILURE	Alarm	Rectifier DC output voltage is high
R03 DC BUS HIGH	Alarm	The rectifier DC output voltage is high, rectifier stop
R05 FREQ TOLER	Alarm	Rectifier input frequency out of tolerant
R06 OVERTEMPERATURE	Alarm	Rectifiers heatsink temperature high
R07 BLACKOUT	Alarm	Short voltage blackout at rectifier AC input
R08 I/P OVERCURRENT	Alarm	Rectifier IGBT saturation alarm
R09 ROTATE PHASE	Alarm	Rectifier input phase sequency incorrect
R14 PFC MANUAL STOP	Alarm	Inverter module stopped rectifier
R15 DC LOW	Alarm	DC BUS voltage is lower than DC rectifier start voltage
R17 BATTERY TEST	Warning	Currently battery test is performing
R18 BOOST CHARGE	Warning	Currently rectifier is in boost charge mode
R19 AC HIGH	Alarm	AC Peak voltage is bigger than 20% of nominal range
R20 INPUT CB OPEN	Warning	Input CB is off
R21 PFC STOP	Warning	Currently Rectifier module stop
R22 POS CHG LIMIT	Warning	(+)Battery charge current limited
R23 NEG CHG LIMIT	Warning	(-)Battery charge current limited

R24 WAITING DC BUS	Warning	Rectifier is waiting DC BUS to raise for startup
R25 BATTERY FAILURE	Warning	Battery test failed
R26 BATT TEMP SENSOR	Warning	Battery temperature sensor is defected or not connected
R27 BATT TEMP HIGH	Warning	Battery ambient temperature is high
R29 PFC RESET	Warning	Rectifier module power on
R30 PLEASE WAIT	Warning	Rectifier waits as adjusted startup delay
R31 RECTIFIER START	Warning	Rectifier is in soft start stage

Panel module alarm codes		
L01 TH1 TEMP HIGH	Warning	TH1 temperature is high
L02 TH2 TEMP HIGH	Warning	TH2 temperature is high
L03 TH1 TEMP LOW	Warning	TH1 temperature is low
L04 TH2 TEMP LOW	Warning	TH2 temperature is low
L05 FAN MAINT	Warning	FAN maintenance time
L06 BATTERY MAINT	Warning	Battery maintenance time
L07 OPT MAINTENANCE	Warning	Optional maintenance time
L08 TH1 SENSOR FAIL	Warning	TH1 temperature sensor failure
L09 TH2 SENSOR FAIL	Warning	TH2 temperature sensor failure
L10 ENTER FAULT RESET	Warning	EL INVERTER is waiting fault reset for startup
L11 BATT CB OPEN	Warning	External interactive battery switch is off
L12 GENERAL MAINT	Warning	General maintenance time
L13 PFC CAN COMM ERR	Warning	PFC module CAN communication timeout

L14 INV CAN COMM ERR	Warning	INV module CAN communication timeout
----------------------	---------	--------------------------------------

Inverter module alarm codes		
INV CODE = 0XXX		Current inverter module status code
A00 INV FAULT = XXXX	Fault	XXXX fault occurred at the inverter module. CALL SERVICE !
A01 O/P OVERCURRENT	Alarm	IGBT saturation alarm on inverter module
A02 OVERTEMP SHUT	Alarm	Overtemperature at inverter power module
A03 BATT HIGH	Alarm	Inverter module measured battery voltage high
A04 OUTPUT V.LOW	Alarm	Inverter output voltage is low
A05 OUTPUT V.HIGH	Alarm	Inverter output voltage is high
A06 OVERLOAD SHUT	Alarm	Overload at EL INVERTER output
A07 SHORT CIRCUIT	Alarm	Short circuit at EL INVERTER output
A08 ON MAINTENANCE	Alarm	Maintenance by-pass switch on
A09 MANUAL BYPASS	Alarm	Load is transferred to by-pass from front panel
A10 BATTERY LOW SHUT	Alarm	Inverter measured battery voltage is low (shutdown level)
A11 REPO STOP	Alarm	External REPO input signal sensed
A12 DC BALANCE BAD	Alarm	Before inverter start filter, capacitors don't discharge
A13 PEAK CURRENT	Alarm	Very high current at the EL INVERTER output
A14 INV NOT START	Alarm	Inverter module start failed
A17 BYPASS FAILURE	Warning	By-pass input voltage failure
A18 BYPASS VOLT	Warning	By-pass input voltage out of tolerance
A19 BYP FREQ.TOLER	Warning	By-pass input frequency out of tolerance
A20 OVERLOAD	Warning	Currently the load exceeded 100% capacity
A21 OVERTEMP	Warning	Currently inverter power module heatsink temperature is high
A22 OUTPUT OFF	Warning	There is no EL INVERTER output voltage
A23 ON BYPASS	Warning	Load is on bypass
A24 REVERSE CURRENT	Warning	Regenerative back feed to EL INVERTER output

If any alarm is shown on the LCD panel without A00 and R00 message EL INVERTER will start automatically if the conditions are normal. But if you see A00 or R00 code with any alarm together you must CALL SERVICE !

If the message is warning EL INVERTER continues to run there is no problem.

To support technical service, status codes are used, each status code tells different event to us.

2.3.8 STATUS CODES

Inverter module status codes

INV L1-L2-L3 phase status codes	
163	During soft start at the end of 4 seconds L1 output voltage is less than 30 volts AC
263	During soft start at the end of 4 seconds L2 output voltage is less than 30 volts AC
363	During soft start at the end of 4 seconds L3 output voltage is less than 30 volts AC

164	During soft start at the end of 4 seconds L1 output voltage is bigger than (output high/2) value
264	During soft start at the end of 4 seconds L2 output voltage is bigger than (output high/2) value
364	During soft start at the end of 4 seconds L3 output voltage is bigger than (output high/2) value
165	During inverter run the L1 phase AC output voltage is bigger than output high alarm level
265	During inverter run the L2 phase AC output voltage is bigger than output high alarm level
365	During inverter run the L3 phase AC output voltage is bigger than output high alarm level
166	During inverter run the L1 phase AC output voltage is less then output low alarm level
266	During inverter run the L2 phase AC output voltage is less then output low alarm level
366	During inverter run the L3 phase AC output voltage is less then output low alarm level
167	L1 phase by-pass SCR must be off but at there is AC voltage at the L1 output of the EL INVERTER
267	L2 phase by-pass SCR must be off but at there is AC voltage at the L2 output of the EL INVERTER
367	L3 phase by-pass SCR must be off but at there is AC voltage at the L3 output of the EL INVERTER
168	L1 phase overload shutdown
268	L2 phase overload shutdown
368	L3 phase overload shutdown
169	Overcurrent occurred on L1 phase longer then allowed time
269	Overcurrent occurred on L2 phase longer then allowed time
369	Overcurrent occurred on L3 phase longer then allowed time
170	On L1 phase momentary short circuit conditions occurred but now inverter is running
270	On L2 phase momentary short circuit conditions occurred but now inverter is running
370	On L3 phase momentary short circuit conditions occurred but now inverter is running
171	On L1 phase output short circuit occurred output shutdown
271	On L2 phase output short circuit occurred output shutdown
371	On L3 phase output short circuit occurred output shutdown
172	Within time window 4 times L1 phase output is less then output low alarm level
272	Within time window 4 times L2 phase output is less then output low alarm level
372	Within time window 4 times L3 phase output is less then output low alarm level
173	Within time window 4 times L1 phase output is higher than output high alarm level
273	Within time window 4 times L2 phase output is higher than output high alarm level
373	Within time window 4 times L3 phase output is higher than output high alarm level
174	On L1 phase EL INVERTER output at last 100 milliseconds the alternance don't changed
274	On L2 phase EL INVERTER output at last 100 milliseconds the alternance don't changed
374	On L3 phase EL INVERTER output at last 100 milliseconds the alternance don't changed
175	On L1 bypass input phase at last 100 milliseconds the alternance don't changed
275	On L2 bypass input phase at last 100 milliseconds the alternance don't changed
375	On L3 bypass input phase at last 100 milliseconds the alternance don't changed
176	On L1 inverter output phase at last 100 milliseconds the alternance don't changed
276	On L2 inverter output phase at last 100 milliseconds the alternance don't changed
376	On L3 inverter output phase at last 100 milliseconds the alternance don't changed

177	L1 phase output current sensor open
277	L2 phase output current sensor open
377	L3 phase output current sensor open

INV L1-L2-L3 phase status codes	
178	Inverter stopped but on inverter L1 phase output still DC voltage sensed
278	Inverter stopped but on inverter L2 phase output still DC voltage sensed
378	Inverter stopped but on inverter L3 phase output still DC voltage sensed
179	During inverter run at last 25 milliseconds the L1 phase output alternance is not changed
279	During inverter run at last 25 milliseconds the L2 phase output alternance is not changed
379	During inverter run at last 25 milliseconds the L3 phase output alternance is not changed
180	At the end of 4 times retry During soft start after 4 seconds still the L1 phase output voltage is less than 30 volts AC
280	At the end of 4 times retry During soft start after 4 seconds still the L2 phase output voltage is less than 30 volts AC
380	At the end of 4 times retry During soft start after 4 seconds still the L3 phase output voltage is less than 30 volts AC
181	At the end of 4 times retry During soft start at the end of 4 seconds L1 output voltage is bigger than (output high/2) value
281	At the end of 4 times retry During soft start at the end of 4 seconds L2 output voltage is bigger than (output high/2) value
381	At the end of 4 times retry During soft start at the end of 4 seconds L3 output voltage is bigger than (output high/2) value
182	During power on L1 phase bypass SCR must be off but at the L1 phase output there is AC voltage
282	During power on L2 phase bypass SCR must be off but at the L2 phase output there is AC voltage
382	During power on L3 phase bypass SCR must be off but at the L3 phase output there is AC voltage
183	L1 phase by-pass SCR must be on but there is only positive alternance at the EL INVERTER output
283	L2 phase by-pass SCR must be on but there is only positive alternance at the EL INVERTER output
383	L3 phase by-pass SCR must be on but there is only positive alternance at the EL INVERTER output
184	L1 phase by-pass SCR must be on but there is only negative alternance at the EL INVERTER output
284	L2 phase by-pass SCR must be on but there is only negative alternance at the EL INVERTER output
384	L3 phase by-pass SCR must be on but there is only negative alternance at the EL INVERTER output
185	L1 phase by-pass SCR must be on but there is no output voltage at the EL INVERTER output
285	L2 phase by-pass SCR must be on but there is no output voltage at the EL INVERTER output
385	L3 phase by-pass SCR must be on but there is no output voltage at the EL INVERTER output

186	Output CB is energized but at the L1 phase output there is only positive alternance
286	Output CB is energized but at the L2 phase output there is only positive alternance
386	Output CB is energized but at the L3 phase output there is only positive alternance
187	Output CB is energized but at the L1 phase output there is only negative alternance
287	Output CB is energized but at the L2 phase output there is only negative alternance
387	Output CB is energized but at the L3 phase output there is only negative alternance
188	Output CB is energized but at the L1 phase output there is no AC voltage
288	Output CB is energized but at the L2 phase output there is no AC voltage
388	Output CB is energized but at the L3 phase output there is no AC voltage
189	During load on by-pass on the L1 output short circuit sensed
289	During load on by-pass on the L2 output short circuit sensed
389	During load on by-pass on the L3 output short circuit sensed
190	On L1 phase output reverse current sensed
290	On L2 phase output reverse current sensed
390	On L3 phase output reverse current sensed
191	During load on inverter, on L1 phase by-pass line leakage current sensed
291	During load on inverter, on L2 phase by-pass line leakage current sensed
391	During load on inverter, on L3 phase by-pass line leakage current sensed

INV DC status codes	
400	DC bus voltage high
401	Inverter controller board power supply 1 out of tolerant
402	Inverter controller board power supply 2 out of tolerant
404	Inverter stop because (+) DC bus voltage is low
405	Inverter stop because (-) DC bus voltage is low
406	Inverter within time window 4 times DC bus voltage is high

INV General status codes	
500	Inverter received remote power off signal from RS232
501	Inverter received remote power off signal from CAN interface
502	Inverter sensed IGBT fault alarm 4 times within time window (30 minutes)
503	Inverter sensed Overtemperature alarm 4 times within time window (30 minutes)
504	Inverter sensed 3 phase AC O/P voltage low alarm 4 times within time window (30 minutes)
505	Inverter sensed 3 phase AC O/P voltage high alarm 4 times within time window (30 minutes)
506	Inverter Timeout error during eprom read or write
507	Inverter Memory checksum error
508	Inverter 3 output phases overloaded output shutdown
509	Inverter maintenance by-pass switch closed
510	Inverter IGBT fault error
511	Inverter overtemperature shutdown
512	Inverter 3 phase AC output voltage low
513	Inverter 3 phase AC output voltage high
514	Inverter output CB energized but still it looks like not energized
515	Inverter output CB not energized but still it looks like energized
516	Inverter fault occurred for restart password required
517	Inverter output CB energized but at the EL INVERTER output there is no 3 phase AC voltage

518	Inverter By-pass voltage is OK but at the EL INVERTER output there is no 3 phase AC voltage
-----	---

INV Control activity status codes	
612	INV Over RS232 interface battery quantity updated
613	INV Over CAN1 interface battery quantity updated
614	INV Over RS232 interface by-pass and output frequency updated
615	INV Over CAN1 interface by-pass and output frequency updated
616	INV Over RS232 interface By-pass and output voltage updated
617	INV Over CAN1 interface By-pass and output voltage updated
618	INV Over RS232 interface factory options updated
619	INV Over CAN1 interface factory options updated
620	INV Over RS232 interface user options updated
621	INV Over CAN1 interface user options updated
622	INV Over RS232 interface general test command received
623	INV Over CAN1 interface general test command received
624	INV Over RS232 interface transfer load to by-pass command received
625	INV Over CAN1 interface transfer load to by-pass command received
626	INV Over RS232 interface transfer load to EL INVERTER command received
627	INV Over CAN1 interface transfer load to EL INVERTER command received
628	INV Over RS232 interface Copy operating RAM to Factory settings zone command received
629	INV Over CAN1 interface Copy operating RAM to Factory settings zone command received
630	INV Over RS232 interface Copy factory settings to operating RAM command received
631	INV Over CAN1 interface Copy factory settings to operating RAM command received
632	INV Over RS232 interface Copy operating RAM to User settings zone command received
633	INV Over CAN1 interface Copy operating RAM to User settings zone command received
634	INV Over RS232 interface regenerative back feed activated
635	INV Over CAN1 interface regenerative back feed activated
636	INV Over RS232 interface fault reset command received
637	INV Over CAN1 interface fault reset command received
638	INV Over RS232 interface short battery test command received
639	INV Over CAN1 interface short battery test command received
640	INV Over RS232 interface long battery test command received
641	INV Over CAN1 interface long battery test command received
642	INV Over RS232 interface battery test cancel command received
643	INV Over CAN1 interface battery test cancel command received
644	INV Over RS232 interface start boost charge command received
645	INV Over CAN1 interface start boost charge command received
646	INV Over RS232 interface stop boost charge command received
647	INV Over CAN1 interface stop boost charge command received
648	INV Over RS232 interface PFC short stop command received
649	INV Over CAN1 interface PFC short stop command received
650	INV Over RS232 interface generator mode start command received
651	INV Over CAN1 interface generator mode start command received
652	INV Over RS232 interface start sleep mode command received
653	INV Over CAN1 interface start sleep mode command received

654	INV Over RS232 interface exit sleep mode command received
655	INV Over CAN1 interface exit sleep mode command received
656	INV Over RS232 interface service login command received
657	INV Over CAN1 interface service login command received
658	INV Over RS232 interface logout command received
659	INV Over CAN1 interface logout command received
660	INV Over RS232 interface user login command received
661	INV Over CAN1 interface user login command received
662	INV over RS232 service level fault reset command received
663	INV over CAN1 service level fault reset command received
664	INV over RS232 delete fault profile memory command received
665	INV over CAN1 delete fault profile memory command received
666	INV over RS232 start regenerative mode command received
667	INV over CAN1 start regenerative mode command received
668	INV over RS232 user level fault reset command received
669	INV over CAN1 user level fault reset command received

PFC rectifier status codes

PFC L1-L2-L3 phase status codes	
1101	PFC L1 phase AC input current LEM sensor error
1201	PFC L2 phase AC input current LEM sensor error
1301	PFC L3 phase AC input current LEM sensor error
1102	L1 phase AC input voltage sample is irregular or DC
1202	L2 phase AC input voltage sample is irregular or DC
1302	L3 phase AC input voltage sample is irregular or DC
1103	PFC AC rectifier input voltage is lower than R2187 on L1 phase input
1203	PFC AC rectifier input voltage is lower than R2187 on L2 phase input
1303	PFC AC rectifier input voltage is lower than R2187 on L3 phase input
1104	PFC AC rectifier input voltage is higher than R2186 on L1 phase input
1204	PFC AC rectifier input voltage is higher than R2186 on L2 phase input
1304	PFC AC rectifier input voltage is higher than R2186 on L3 phase input
1105	PFC L1 phase AC peak input voltage is bigger 20% from nominal range value
1205	PFC L2 phase AC peak input voltage is bigger 20% from nominal range value
1305	PFC L3 phase AC peak input voltage is bigger 20% from nominal range value
1106	PFC L1 phase AC input current limited
1206	PFC L2 phase AC input current limited
1306	PFC L3 phase AC input current limited

PFC DC status codes

1400	PFC +DC bus voltage is higher than R2131 adjustment
1401	PFC -DC bus voltage is higher the R2131 adjustment
1402	PFC DC LEM current sensor error
1403	PFC module +DC BUS voltage high alarm repeated 4 times within R2166 time window
1404	PFC module -DC BUS voltage high alarm repeated 4 times within R2166 time window
1405	PFC board isolated power supply voltage failure
1406	PFC rectifier power component DC leakage sensed

PFC General status codes	
1500	PFC remote emergency power off command received from RS232 or CAN interface
1501	PFC IGBT saturation alarm
1502	PFC overcurrent alarm
1503	PFC input CB not energized but still it looks like energized
1504	PFC input CB energized but still it looks like not energized
1505	PFC eeprom timeout error
1506	PFC eeprom memory error
1507	PFC module IGBT fault alarm repeated 4 times within R2165 time window
1508	PFC module overtemperature alarm repeated 4 times within R2167 time window
1509	PFC 3 phase AC power failure on EL INVERTER input (2.5 seconds later after mains failure)
1510	PFC 3 phase AC rectifier input voltage is high (2.5 seconds later after mains failure)
1511	PFC AC power failure on L1-L2 phases (phase to phase)
1512	PFC AC power failure on L1-L3 phases (phase to phase)
1513	PFC AC power failure on L2-L3 phases (phase to phase)
1514	PFC AC input voltage high on L1-L2 phases (phase to phase)
1515	PFC AC input voltage high on L1-L3 phases (phase to phase)
1516	PFC AC input voltage high on L2-L3 phases (phase to phase)

PFC Control activity status codes	
1612	PFC Battery quantity updated over RS232 interface
1613	PFC Battery quantity updated over CAN interface
1614	PFC rectifier Input frequency range updated over RS232 interface
1615	PFC rectifier Input frequency range updated over CAN interface
1616	PFC factory settings updated over RS232 interface
1617	PFC factory settings updated over CAN interface
1618	PFC rectifier Input AC voltage range updated over RS232 interface
1619	PFC rectifier Input AC voltage range updated over CAN interface
1626	PFC over RS232 interface Test AC input signals command received
1627	PFC over CAN interface Test AC input signals command received
1628	PFC over RS232 interface copy operating RAM to Factory settings memory command received
1629	PFC over CAN1 interface copy operating RAM to Factory settings memory command received
1630	PFC over RS232 interface Copy factory settings to operating RAM command received
1631	PFC over CAN1 interface Copy factory settings to operating RAM command received
1632	PFC over RS232 interface Copy operating RAM to User settings memory command received
1633	PFC over CAN1 interface Copy operating RAM to User settings memory command received

1636	PFC over RS232 memory checksum lock command received
1637	PFC over CAN1 memory checksum lock command received
1638	PFC over RS232 interface start short battery test command received
1639	PFC over CAN1 interface start short battery test command received
1640	PFC over RS232 interface start long battery test command received
1641	PFC over CAN1 interface start long battery test command received
1642	PFC over RS232 interface cancel battery test command received
1643	PFC over CAN1 interface cancel battery test command received
1644	PFC over RS232 interface start boost charge mode command received
1645	PFC over CAN1 interface start boost charge mode command received
1646	PFC over RS232 interface stop boost charge command received
1647	PFC over CAN1 interface stop boost charge command received
1648	PFC over RS232 interface short stop command received
1649	PFC over CAN1 interface short stop command received
1650	PFC over RS232 interface start generator mode command received
1651	PFC over CAN1 interface start generator mode command received
1652	PFC over RS232 interface enter sleep mode command received
1653	PFC over CAN1 interface enter sleep mode command received
1654	PFC over RS232 interface exit from sleep mode command received
1655	PFC over CAN1 interface exit from sleep mode command received
1656	PFC over RS232 interface service login command received
1657	PFC over CAN1 interface service login command received
1658	PFC over RS232 interface logout command received
1659	PFC over CAN1 interface logout command received
1660	PFC over RS232 interface user login command received
1661	PFC over CAN1 interface user login command received
1662	PFC over RS232 interface service level fault reset command received
1663	PFC over CAN1 interface service level fault reset command received
1664	PFC over RS232 delete fault profile memory command received
1665	PFC over CAN1 delete fault profile memory command received
1666	PFC over RS232 interface back feed regenerative energy to mains input command received
1667	PFC over CAN1 interface back feed regenerative energy to mains input command received
1668	PFC over RS232 user level fault reset command received
1669	PFC over CAN1 interface user level fault reset command received

For detailed description of the status codes please refer to service

6.2 ALARM MESSAGES AND TROUBLESHOOTING

Alarm codes and messages are showed at the 4.line of the LCD panel. Various messages tells different events. At some messages user can make some simple controls and they can decide that they must call service or not.

NOTE: If **R00 REC FAULT = XXXX** or **A00 INV FAULT = XXXX** message is shown on the LCD panel the other alarm or warning messages will not be shown.

R00 REC FAULT = XXXX

Call service

R01 AC INPUT HIGH

The input voltage of the EL INVERTER is very high check the AC input voltage if really high wait until the voltage is normal.

R02 LINE FAILURE

The input voltage of the EL INVERTER is very low, check the AC input voltage if the input voltage is low wait until the AC input voltage is normal.

R03 DC BUS HIGH

Call service

R05 FREQ TOLER

The AC input voltage frequency of the EL INVERTER is out of tolerance wait until the input frequency is normal.

R06 OVERTEMPERATURE

Overtemperature at rectifier module call service.

R07 BLACKOUT

There is a short blackout at the AC input voltage of the EL INVERTER, this is temporary wait until the AC input voltage is normal.

R08 I/P OVERCURRENT

Call service

R09 ROTATE PHASE

The phase sequency at the EL INVERTER input is reverse please refer to technical personnel to provide correct phase sequence.

R14 PFC MANUAL STOP

This message shows that the rectifier is stopped for any alarm reason check the other alarm shown together with this alarm.

R15 DC LOW

DC BUS voltage or battery voltage is very low wait 10 minutes then call service.

R17 BATTERY TEST

For 30 seconds EL INVERTER is performing battery test at the end of the test EL INVERTER decides batteries are OKEY or not, then EL INVERTER returns to normal operation automatically.

R18 BOOST CHARGE

For 10 hours boost charge mode is activated from EL INVERTER, at the end of 10 hours EL INVERTER returns to normal charge mode.

R19 AC HIGH

The AC input voltage of the EL INVERTER is 20% higher than nominal input voltage, wait until the AC input voltage is normal.

R20 INPUT CB OPEN

The input of the EL INVERTER is isolated from mains power with contactor, this message will be shown with another alarm always. Check the other alarm code.

R21 PFC STOP

The rectifier is stopped itself and wait it must start again, another alarm code shows the reason of the rectifier stop. Wait for 1 minute if alarm continues call service.

R22 POS CHG LIMIT, R23 NEG CHG LIMIT

This message is normal if the battery charge current is reached to limit value during battery charge.

R24 WAITING DC BUS

The DC BUS voltage of the EL INVERTER is not enough to startup wait 2 minutes if message continues call service.

R25 BATTERY FAILURE

At the last battery test one or more defective batteries were found, call service.

R26 BATT TEMP SENSOR

Battery temperature sensor malfunctioned, call service.

R27 BATT TEMP HIGH

If batteries are located outside of the EL INVERTER cabinet, check battery ambient temperature if hot use air cooling system. If batteries are internal check the EL INVERTER ambient temperature if normal call service.

L02 TH2 TEMP HIGH, L04 TH2 TEMP LOW

EL INVERTER TH2 cabinet inside temperature is out of tolerance check the followings:

- If EL INVERTER air inlets and outlets covered by dust clean
- If any material prevents air flow at EL INVERTER air inlets or outlets take the material
- If EL INVERTER ambient temperature is high then 45 C, use air cooling system

L05 FAN MAINT

Maintenance due of the cooling fans of the EL INVERTER, call service.

L06 BATTERY MAINT

Maintenance due of the EL INVERTER batteries, call service.

L08 TH1 SENSOR FAIL, L09 TH2 SENSOR FAIL

TH1 or TH2 temperature measurement sensors are defective, call service.

L10 ENTER FAULT RESET

Call service

L11 BATT CB OPEN

The battery switch of the EL INVERTER is OFF, in this case EL INVERTER runs normally but if mains failure alarm occurs the output voltage of the EL INVERTER shutdown. Please turn ON the battery switch.

L12 GENERAL MAINT

General maintenance due, call service.

L13 PFC CAN COMM ERR

Call service.

L14 INV CAN COMM ERR

Call service.

A00 INV FAULT = XXXX

Call service.

A01 O/P OVERCURRENT

Check the new load which are connected to EL INVERTER nowadays the total load power maybe exceeds maximum power of the EL INVERTER. Otherwise call service.

A02 OVERTEMP SHUT

Inverter modules heatsink temperature is out of tolerance check the followings:

- If EL INVERTER air inlets and outlets covered by dust clean
- If any material prevents air flow at EL INVERTER air inlets or outlets take the material
- If EL INVERTER ambient temperature is high then 45 C, use air cooling system

A03 BATT HIGH

The DC BUS voltage or battery voltage of the EL INVERTER is high, if inductive load is used this event sometimes occurs if alarm continues call service.

A04 OUTPUT V.LOW

The output voltage of the inverter is low call service.

A05 OUTPUT V. HIGH

The output voltage of the inverter is high call service.

A06 OVERLOAD SHUT

The total load which is connected to the EL INVERTER is exceeded 100% capacity of the EL INVERTER if message continues call service they will check EL INVERTER, but probably you need higher power range EL INVERTER.

Note: Some load inrush currents cause overload event then current is normal.

A07 SHORT CIRCUIT

There is a short circuit at the output of the EL INVERTER check installation and loads.

A08 ON MAINTENANCE

The maintenance by-pas switch of the EL INVERTER is ON <1>position, there is a lock on this switch which prevents unauthorized personnel use.

A09 MANUAL BYPASS

The load is transferred to by-pass from EL INVERTER command menu, transfer the load to the inverter.

A10 BATTERY LOW SHUT

The DC BUS or battery voltage of the EL INVERTER is low. If the main is OKEY call service. If there is no mains voltage wait until mains OKEY EL INVERTER will start automatically.

A11 REPO STOP

External repo button pressed, to restart turn off and on the EL INVERTER

A12 DC BALANCE BAD

Call service

A13 PEAK CURRENT

Very high current measured at the EL INVERTER output, check loads.

A14 INV NOT START

Call service

A17 BYPASS FAILURE, A18 BYPASS VOLT, A19 BYP FREQ.TOLER

The input of the EL INVERTER or by-pass input of the EL INVERTER voltage or frequency is out of tolerance, wait until the voltage is normal if message continues long time check input fuses ,switches etc. at the distribution panel.

A20 OVERLOAD

EL INVERTER is currently running but the load percentage exceeded 100% capacity of the EL INVERTER, if this situation continues inverter will stop after a delay. Check the loads at the EL INVERTER output.

A21 OVERTEMP

Inverter modules heatsink temperature is high check the followings:

- If EL INVERTER air inlets and outlets covered by dust clean
- If any material prevents air flow at EL INVERTER air inlets or outlets take the material
- If EL INVERTER ambient temperature is high then 45 C, use air cooling system

A22 OUTPUT OFF

During mains failure if the battery backup time is finished this message is normal, there is no energy so the EL INVERTER shutdown the output voltage.

If this message is permanent call service, otherwise wait until the message is deleted automatically from LCD screen.

A23 ON BYPASS

From any reason EL INVERTER transferred the load to bypass, check the other alarm code which shown together with this alarm it shows the by-pass reason.

If the EL INVERTER stays in this position for a long-time call service.

A24 REVERSE CURRENT

Any load such as motors are connected to EL INVERTER output and the load in regenerative mode, it is applying reverse energy to the EL INVERTER output. Call service

A25 INV RESET

This is the power on indicator of the inverter module, during power on for 10 seconds this message will be shown at the end of 10 seconds the message will be cleared.

A26 BATTERY LOW

The DC BUS or battery voltage of the EL INVERTER is low, still EL INVERTER is running but DC voltage is going down.

If this alarm occurs during mains failure it means that there is no energy from batteries this is normal.

But if this alarm occurs during mains OKEY call service.

A27 GENERATOR MODE

EL INVERTER is running in generator mode when generator set stops EL INVERTER returns to normal operating mode automatically.

A28 O/P PHASE LOSS

Call service

A29 SYNCHRON BAD

This is only a warning that shows the inverter and bypass voltages are not synchronized to each other ,there is nothing to do to wait until they match.

A30 SHORT CIRCUIT

Shorter than 4 alternance (40 milliseconds) short circuit occurred at the output of the EL INVERTER, now EL INVERTER is running but you must check the installation and loads.

A31 OUTPUT SWITCH

The output switch of the EL INVERTER is OFF <0>position, turn on <1>position the output switch.

A32 SERVICE LOGIN

Service personnel logged in to EL INVERTER this is only warning.

A34 BYP ROTATE PHASE

The phase sequency of the bypass source does not match the EL INVERTER output phase sequency. Please check the by-pass phase sequency if wrong change phases.

A35 INV STOP

The message shows that the inverter module stopped for any reason ,check the other alarm code which is shown together with this message.

A36 INV DC DOWN

Call service

A37 AC CURR LIMIT

Alarm shows us the output current is very high (higher than 150%) the EL INVERTER limited the output current. This status is temporary, but if it continues call service.

A38 FUSE FAILURE

Call service

A39 PSP FAILURE

Call service

A43 USER LOGIN

User logged in to EL INVERTER. This is only a warning.

A45 SERV.PASSWORD

Call service, EL INVERTER start impossible.

CHAPTER 7 – COMMUNICATION

7.1 INTRODUCTION

The following external connections are available for EL300DSP Series EL INVERTERS.

- Communication by serial port connection.
- Dry contact (interface board) connections.
- Remote monitoring panel.

Using one of the above communication options is satisfactory for remote monitoring and control in most of the systems. But some systems may use 2 or 3 of the above options at the same time. In this case the accessories group produced by BPC may help to make appropriate solutions.

7.2 SERIAL PORT CONNECTION

Two serial communication port is included in the EL300DSP Series EL INVERTER cabinet (com1 and com2). Both of them may be used for user communication. But in service status duty of com2 port is changed and set as service port in Options Menu.

All data of EL INVERTER can be accessed by this communication way. All the voltage and current values measured by EL INVERTER, alarms, warning and status messages can be monitored.

The maximum length for RS232 communication cable should be 25 meters. For remote panel and EL INVERTER connection the same pin configuration is valid. Connection terminals of RS232 cable is shown below for com1 and com2 ports:

EL INVERTER Side	Panel Side
9 Tx	2 Rx
7 Gnd	5 Gnd
6 Rx	3 Tx

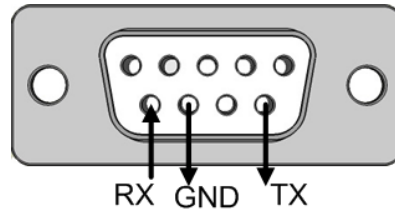

7.3 DRY CONTACT CONNECTIONS

Some important events of the EL INVERTER can be monitored or controlled by these connections. These functions are listed below:

RL5	RL6	RL7	RL8	RL9	RL10	RL11		RL1				RL2	RL3	RL4						
CSD CLOSED	LOAD ON INVERTER	BATT. TEST ACTIVE	GENERAL FAULT	INVERTER HEALTHY	CHARGER FAULT	DEEP DISCHG. PROT.	FAR COIL	PHASE FAIL	EXT. TEST BUTTON	MAINT. NONMAINT	24V OIP CONTACTOR	EXT. BATT. TEST	BATT. CB	BATT. SW	GENIN1	EPO	TH1	MAINS FAILURE	BATT. LOW	LOAD ON BYPASS

Figure 7.1

7.3.1 CONTROLS

BATT SW

Provides an output to external battery breaker. Enables the tripping of external battery breaker during specific set conditions.

GENIN1

Allows the Inverter to know when Generator is in operation.

The inverter can be set to open its synchronisation window during generator operation.

The Inverter can be set to reduce charging current during generator operation.

EPO

An external EPO circuit can be connected to the EPO terminals.

The external circuit must be 'normally open' to the EPO terminals.

If the EPO circuit is operated (short-circuit) the PowerPro EL 300DSP will shut down and disconnect the load power.

The EPO terminals are volt-free and should be connected using a screened cable with 1 pair (0.5 mm²) and maximum length of 100m.

Note: If an external EPO circuit is not connected, a shorting link must be connected to the EPO terminals (as shown).

The terminals can be changed to NC in the display firmware.

TH1

The battery temperature can be measured by a thermocouple sensor that is attached to the TH1 connection, supplied as an option from BPC.

TH1 will enable the ability to provide temperature compensation charging.

FAR COIL

A fire Alarm Relay (FAR COIL), with a 24V DC coil input is mounted on the ELOPT01 board and its coil is connected via terminals 1 and 2 of CN13, to the 24V DC control output of the remote Fire Alarm Panel. Under normal operating conditions this relay is energized and if the external 24V DC supply to terminals 1 and 2 is lost (in case of a fire alarm) the FAR will be de-energized by forcing the load on to the inverter and de-energizing the none-maintained contactor, regardless of the position of the switch connected across CN16 terminals of MAINT. / NON-MAINT. That means under fire alarm conditions the load is turned on, anyway.

PHASE FAIL

An external phase failure device, via external phase fail terminals (two terminals of CN14 on the ELOPT01 board, labelled as PHASE FAIL) can also be used to externally monitor a phase which is not supplying the machine. Two terminals of CN14 should normally be kept shorted under normal operating conditions. When the external phase failure device opens these terminals, the output is switched to inverter.

EXT. TEST BUTTON

A N/C momentary TEST BUTTON is connected across the two terminals of CN15 on the ELOPT01 board (labelled as EXT. TEST BUTTON), providing an immediate test that the system is working OK by forcing the load on to the inverter and de-energizing the none-maintained contactor if fitted. (The NC contacts of the contactor should be used for connecting the load to the Inverter outputs.)

MAINT / NON MAINT

Two terminals of CN16, MAINT. / NON-MAINT on the ELOPT01 board are for connection to an external switch so the end user can control the output of the system (i.e., the lights are on or off) if a NC none-maintained contactor is used in series with the Inverter output. For maintained operation this switch (connected between two terminals of CN16) should be “open” and for non-maintained operation it should be “closed”. The none-maintained contactor mentioned above should have a coil voltage of 24V DC, and this voltage is available across the two terminals of CN17 on the ELOPT01 board (max 3 Amps). Even if this switch is closed for non-maintained operation, the non-maintained contactor is de-energized, and the lights are turned on in case of power failure.

24V O/P CONTACTOR

24VDC output for external output contactor.

Contactors should be Normally closed and directly fed from this supply.

In the event of a mains failure the contactor will close.

In the event of FAR COIL / PHASE FAIL / EXT TEST / (MAINT/NON MAINT) being activated the contactor will close

EXT. BATT TEST

NC connection, opening this connection provides an immediate test that the system is working OK by forcing the load on to the inverter and de-energizing the none-maintained contactor if fitted. (The NC contacts of the contactor should be used for connecting the load to the Inverter outputs.)

Suitable for connecting to DALI / KNX and external lighting controls to perform regular test.

7.3.2 DRY PORT CONTACTS

The PowerPro EL 300DSP provides eleven hard-wired ‘system status’ outputs that can be used to drive remote signalling and/or monitoring facilities. These outputs are switched by volt-free relay contacts and are normally closed/open (selected in display). The contacts are rated for 42VDC @ 0.5A.

As shown in Figure 7.1, the eight switched alarm outputs are:

- **RL1 – BATT CB**
Battery Circuit Breaker is Open or Closed
- **RL2 – MAINS FAILURE**
Changes state if the input voltage or frequency is out of tolerance.
- **RL3 – BATTERY LOW**
Changes state if the battery voltage goes below its set value during a mains failure.
- **RL4 – ON BYPASS**
Changes state if Output is being fed from Bypass Line or in Changeover Mode.
- **RL5 – CSD CLOSED**

Changes state if the external contactor on output is closed.

- **RL6 – ON INVERTER**
Changes state if Output is being fed from Inverter.
- **RL7 – BATTERY TEST ACIVE**
Changes state if a battery test alarm has been received.
- **RL8 – GENERAL FAULT**
Changes state if the any fault alarm if activated from the EL300DSP.
- **RL9 – INVERTER HEALTHY**
Changes state if the EL300DSP is healthy with no alarms.
- **RL10 – CHARGER FAULT**
Changes state if the Charger goes out of tolerance.
- **RL11 – DEEP DISCHARGE PROTECTION**
Changes state if the deep discharge protection is activated.

Connections to these terminals should be made using a screened cable with 1 pair (0.5 mm²) and maximum length of 100m.

7.3.4 SNMP CARD SLOT

Simple Network Management Protocol (SNMP) is a world-wide, standardised communication protocol that can be used to monitor any network-connected device via a simple control language and display the results in an application running within a standard web browser.

An SNMP card slot, designed to house a Modem/Ethernet SNMP adapter card, is located behind a cover plate on the right-hand side of the control panel. To fit the card, you must remove the cover plate, insert the card into its connector then secure it in place using the screws that you removed when taking off the cover plate.

The SNMP adapter card contains an RJ-45 Ethernet connector which allows the PowerPro EL 300DSP to be connected to a network using a standard CAT-5 network cable. Once connected, the system management software agent that is preinstalled in the SNMP adapter monitors the PowerPro EL 300DSP operation and outputs its data in SNMP format to the connected network.

The communication exchanged between the PowerPro EL 300DSP and network enables event/alarm emails, server shut down (with optional licenses) and other tasks to be performed. It can also be integrated with BMS software over a local area network (LAN) for SNMP.

The SNMP adaptor requires a PC with terminal connections, and for normal operation at least one Ethernet connection.

Note: SNMP connectivity can also be implemented using an external SNMP adapter connected to the RS232 output.

CHAPTER 8 – TECHNICAL SPECIFICATION

8.1 GENERAL SPECIFICATIONS

Model	EL 310	EL 320	EL 330	EL 340	EL 360
Nominal Output Rating (CosØ : 0,8) kVA	10	20	30	40	60
Nominal Output Rating (CosØ : 1) kW	9	18	27	36	54
Audible Noise	<57 dB	<62dB		<64dB	
Efficiency (Load Dependant)	Up to 94% Inverter Mode / Up to 98% Changeover Mode				
Operating Temperature (Ambient)	0-40 °C				
Altitude	<1000 meters (Above Sea level)				
Ventilation	Forced				
Relative Humidity	< 90%				
Protection Degree	IP 20				
Standards	EN 62040-1, EN 62040-2, EN62040-3, EN 60950-1 EN 61000-4-2, EN 61000-4-3, EN 61000-4-4, EN 61000-4-5, EN 61000-4-6, EN 61000-4-8, EN 60529, EN50171, ICEL1009				
Transport	Packaged and On Pallet				

8.2 RECTIFIER SPECIFICATIONS

Model	EL 310	EL 320	EL 330	EL 340	EL 360
Nominal Input Voltage	380 / 400 VAC 3 phase + N, +20 - 25%				
Nominal Input current (A) per phase @100% resistive load, No charge current. (230V)	14	28	43	57	85
Max Input current (A) per phase @100% resistive load, Full charge current. (230V)	19	41	56	76	111
Max Input current (A) per phase @120% resistive load, Full charge current. (230V)	22	47	66	89	131
Input Frequency Range	50 Hz, +/- 5%				
Input Power Factor	>0.99				
Input Voltage distortion	<10 %				
Input THDi	<5%				
Input Protection	Fuses, Voltage & Frequency tolerance, Input power limit, Input PFC				

8.3 BATTERY SPECIFICATIONS

Model	EL 310	EL 320	EL 330	EL 340	EL 360
Battery Type	Sealed Lead Acid VRLA / Ni-Cad				
Number of Blocks	60 Batteries (+/-30)				
Number of Cells	360				
Float voltage	810Vdc (+/-405 Vdc)				
Battery Cut Off voltage	600Vdc (+/-300 Vdc)				
Charger Max (A)	5.5	13	14	20	27
Battery Installation	External				
Battery Test Automatic	Standard every 72 Hours (Adjustable)				
Battery Protection	Polarity Protection/ Short Circuit Protection /Automatic Circuit Breaker / Fuses				

8.4 INVERTER SPECIFICATIONS

Model	EL 310	EL 320	EL 330	EL 340	EL 360
Inverter Bridge	IGBT Technology				
Nominal Output Voltage	380 / 400 VAC 3 phase + N				
Nominal Output Current	13A	26A	39A	52A	78A
Output Frequency	50 Hz (60 Hz on Request)				
Output Frequency Tolerance - Free Running - Line Synchronized	± 0,2 % ± 2 %				
Overload Capability	120% Load: Continuous 125-150% Load: 1 min 150-180% Load: 1second >180% Load : Bypass				
Harmonic Distortion - Linear Load - Non-Linear Load	< 2 % < 5 %				
Crest Factor	3/1				
Output Waveform	Sine Wave				
Short Circuit Protection	Electronic Short Circuit Protection				

8.5 BYPASS SPECIFICATIONS

Primary Components	Electronic SCR Switch
Nominal Voltage -V	380 / 400 VAC 3 phase + N
Nominal Frequency - Hz	50 Hz \pm 5%
Retransfer: Static By-Pass to Inverter	Automatic And Manual
Overload Capability	150 – 200 % Continuously
Manual By-Pass	Without Interruption

8.6 OPTIONAL SPECIFICATIONS

Input/output voltage	110/208 VAC 3 Phase
Input transformer	Galvanic isolation transformer at the input & output
Adaptors	SNMP, MODBUS, Remote Monitoring Panel, RS485
Communication	RS232 & DRY Contacts

8.7 MECHANICAL SPECIFICATIONS

Model	EL 310	EL 320	EL 330	EL 340	EL 360
Dimension (h x w x d)	Base 1035 x 400 x 855 With Roof 1060 x 460 x 855		Base 1450 x 515 x 855 With Roof 1470 x 555 x 920		
Weight (without battery) kgs	91	101	175	180	195
Protection Level	IP20				
Colour	Black				